

88 APR 29 PH 3:44

384 No.  
2 copy  
1 cert

FREDA WRIGHT  
CLERK OF CIRCUIT COURT  
INDIAN RIVER CO., FLA.

DECLARATION OF CONDOMINIUM  
ESTABLISHING  
RIVER RUN DOCK  
A CONDOMINIUM

BY Christina D.C.  
Storck

This Declaration (the "Declaration"), made this 1st day of June, 1987, by MULLER ENTERPRISES, INC., a Florida corporation, having its principal place of business at 6100 River Run Drive, Sebastian, Indian River County, Florida (hereinafter sometimes referred to as "Developer"), for itself, its successors, grantees and assigns:

WHEREIN, Developer makes the following declaration and submission:

1. Purpose. The purpose of this Declaration is to submit the docks, boat slips, walkways, dolphins and waterways herein described and the improvements thereon to the condominium form of ownership and use in the manner provided by Chapter 718, Florida Statutes, 1983, herein called "the Condominium Act", as and for a plan of condominium ownership for such real property and improvements thereon as hereinafter described.

a. Name and address. The name by which this condominium is to be identified is RIVER RUN DOCK, a Condominium (hereinafter referred to as the "Condominium"), and its address is 6100 River Run Drive, Sebastian, Florida 32958.

b. The Land. The land owned by Developer which is hereby submitted to the condominium form of ownership is located in Indian River County, Florida (the "Land"). A description thereof is attached as Exhibit A.

2. Definitions.

a. Additional Facilities means those facilities, more particularly described in paragraph 12 hereof, other than the Condominium Property as hereinafter defined, which are either located on land, and are themselves, owned by the Association as hereinafter defined, or are located upon land owned by other condominiums for which the said Association has operating responsibilities.

b. Assessment means that share of the funds required for the payment of Common Expenses (as hereinafter defined) which, from time to time, is to be paid by each Boat Slip Owner (as hereinafter defined).

c. Association means RIVER RUN OF SEBASTIAN CONDOMINIUM ASSOCIATION, INC., a Florida corporation not for profit, and its successors and assigns, responsible for the operation of the Condominium.

d. Common Expenses include:

(1) Expenses of administration and expenses of maintenance, operation, repair or replacement of the Common Property or Additional Facilities, if any, and of those portions of the Docks, walkways, boat slips, dolphins and waterways to be maintained by the Association.

(2) Expenses declared to be Common Expenses by provisions of this Declaration or of the By-laws of the Association.

(3) Any valid charge against the Condominium Property (as hereinafter defined) as a whole.

RETURN TO: COMMERCIAL TITLE SERVICES

e. Common Elements means the portions of the Condominium property not included in the boat slips.

f. Common Surplus means the excess, if any, of all receipts of the Association over the Common Expenses.

g. Condominium Property means and includes the land of the Condominium, all improvements thereon, the Common Property, Limited Common Property, and all easements and rights appurtenant thereto.

h. Institutional Mortgage means a mortgage held by a bank, savings and loan association, insurance company, union pension fund, licensed mortgage company, or any FNMA approved lender.

i. Singular, Plural Gender. Whenever the context so permits, the use of the plural shall include the singular, the singular the plural, and the use of any gender shall be deemed to include all genders.

j. Unit means Boat Slip as shown on Dock Plan - Exhibit B as defined by the Condominium Act.

k. Unit Owner means unit owner, as defined by the Condominium Act.

1. Utility Services as used in the Condominium Act and as construed with reference to this Condominium, and as used in the Declaration and By-laws of the Association, shall include limited electric power, cold water.

3. Submission Statement. The Condominium is described and established as follows: The Developer hereby submits the Land and all improvements erected or to be erected thereon, all easements, rights and appurtenances belonging thereto, and all other property, real, personal or mixed, intended for use in connection therewith, to the condominium form of ownership and use in the manner provided by the Condominium Act as it exists on the date hereof. Survey and Description. A survey of the Land, showing the location of the improvements, Common Property, and easements, is attached as Exhibit B, a survey of the entire River Run development and a subsidiary sketch of easements is attached as Exhibit C. It is anticipated that this Condominium will be ancillary to no more than five (5) separate residential condominiums to be established as a community of condominiums by the Developer plus one dock condominium and that the Association will be liable for the operation of all of said condominiums. The declaration of condominium for each of said condominiums shall be in substantially the same form, as permitted by law. No statements contained herein shall be construed so as to require the Developer to submit any land to the condominium form of ownership, except the land submitted by this Declaration as shown on Exhibit A.

4. Dock Plan, and Elevations. One sheet of dock elevations (Exhibit D) is attached hereto and are presented in sufficient detail, taken together with Exhibit B, to identify each Unit and the Common Property, and to provide accurate representation of their locations and dimension. For purposes of identification,

Units located upon the Condominium Property are given identifying numbers and no Unit bears the same identifying number as does any other Unit.

5. Certificate. A certificate of a surveyor authorized to practice in the State of Florida, certifying that the construction of the improvements described is sufficiently complete so that the aforementioned survey, plot plans, floor plans and graphic descriptions, together with the wording of the Declaration, are an accurate representation of the location and dimensions of the improvements described, and further that with such material there can be determined therefrom the identification, location and dimensions of each Unit, all easements, and the Common Property, is attached hereto as Exhibit E.

6. Easements. Each of the following easements is hereby created as a covenant running with the land of the Condominium, to-wit:

a. Perpetual non-exclusive easement in Common Property. The Common Property shall be, and the same is hereby declared to be subject to a perpetual non-exclusive easement in favor of all of the Unit Owners in this and other condominiums for which the Association has operating responsibilities, for their use and the use of their immediate families, guests and invitees, for all proper and normal purposes, and for the furnishing of services, utilities and facilities which are reasonably intended for the enjoyment of said Unit Owners, and as the same may exist or be necessary or desirable for the furnishing of the same to units or other areas of such condominiums from time to time. Notwithstanding anything above provided in this paragraph to the contrary, the Association shall have the right to establish rules and regulations pursuant to which Unit Owners may be entitled to the exclusive use of a parking space or spaces other than those parking spaces assigned and appurtenant to a particular unit.

b. Easement of air space. Each Unit Owner shall have an exclusive easement for the use of air space occupied by said Unit as it exists at any particular time and as said Unit may lawfully be altered or reconstructed from time to time, which easement shall be terminated automatically in any air space which may be vacated from time to time.

c. Utilities. Easements shall exist as may be required for utility services in order to adequately serve the Condominium and any other condominiums for which the Association has operating responsibilities; provided, however, that easements through a Unit shall only be according to the plans and specifications for the Boat Dock Condominium or as the Boat Docks are actually constructed, unless approved, in writing, by the Unit Owner. An easement shall exist throughout the Common Property for the purpose of installation, maintenance, repair and replacement of all water and power lines, conduits, wires, poles, and any and all other equipment or machinery necessary or incidental to the proper functioning of any utility system.

d. Traffic. An easement shall exist for pedestrian traffic over, through and across sidewalks, paths, walks, and other portions of the Common Property as may from time to time be intended and designated for such purpose and use and as may be necessary to provide reasonable access to public ways, and for vehicular and pedestrian traffic over, through and across such portions of the Common Property as may from time to time be paved and intended for such purpose and as may be necessary to provide reasonable access to public ways; and such easement shall be for the use and benefit of the Unit Owners, Institutional Mortgagees and/or tenants in the Condominium and other condominiums for which the Association has operating responsibilities, or members of their respective families and their social guests; provided, however, nothing herein shall be construed to give or create in

any person the right to park upon any portion of the Common Property of the Condominium Property except to the extent that space may be specifically designated and assigned for parking purposes.

e. Easement for Unintentional and Non-Negligent Encroachments. If a Unit shall encroach upon any Common Property, or upon any other Unit, by reason of original construction or by the non-purposeful or non-negligent act of the Unit Owner or Developer, then an easement appurtenant to such encroaching unit to the extent of such encroachment shall exist so long as such encroachment shall exist. If any Common Property or shall encroach upon any unit by reason of original construction or the non-purposeful or non-negligent act of the Association or the Developer, then an easement appurtenant to such Common Property to the extent of such encroachment shall exist so long as such encroachment shall exist.

f. Other Easements. There are also created hereby such other easements as are described and set forth in, and created by, the Easement Deed appended to this Declaration of Condominium as Exhibit F.

g. Additional Easements. The Association, on its behalf and on behalf of all Unit Owners (each of whom hereby appoints the Association as his attorney-in-fact for this purpose), shall have the right to grant such additional electric, gas or utility or service or other easements, or relocate any existing easements or drainage facilities, in any portion of the Condominium Property, as the Association shall deem necessary or desirable for the proper operation and maintenance of the Condominium Property, or any portion thereof, or for the general health or welfare of the Unit Owners, or for the purpose of carrying out any provisions of this Declaration or otherwise, provided that such easements or the relocation of existing easements will not prevent or unreasonably interfere with the reasonable use of the Units for their intended purposes. The Association, on behalf of itself and all Unit Owners (as such Unit Owners' attorney-in-fact), shall also have the right to transfer title to utility-related equipment, facilities or material to any public utility company or governmental agency which is assuming the obligation to maintain such equipment, facilities or material. In connection with the foregoing, bills of sale may be granted for items of personal property owned or governed by the Association. Furthermore, the Association shall have the authority to take any other action, on behalf of itself and all Unit Owners (as such Unit Owners' attorney-in-fact), to satisfy the requirements of any public utility company or governmental agency to which any such utility-related equipment, facilities or material are to be so transferred.

7. Improvements - General Description.

a. The Condominium consists of 19 docks and connecting walkways with a total of 44 slips and navigable waterways located on a parcel of land to the east of U.S. Highway 1.

b. Other Improvements may include, but are not limited to, landscaping, automobile parking areas, walkways and entrance ways; all of which are a part of the Common Property, except as is stated otherwise herein.

8. Unit boundaries. Each Unit shall include the area of waterway adjacent to a dock or seawall as shown on Exhibit B from the water's surface down to the underlying bottom land and shall include the air space above the designated area.

9. Common Elements. The "common elements" of the Condominium have heretofore in this Declaration been defined as "Common Property" (see paragraph 2, subparagraph e.), which consists, as stated, of the land of the Condominium and all other parts of the Condominium Property not within the Units, or which are not specified as Limited Common Property, and all tangible personal property which is used in the maintenance and operation of the Condominium. A Unit Owner shall not be deemed to own pipes, wires, conduits, or other public utility transmission devices running through any Unit which are utilized for or serve more than one Unit, which items are, by these presents, hereby made a part of the Common Property. The Common Property of the Condominium shall also include its interest in property owned by the Association for the use and benefit of all Unit Owners in the community of condominiums as set forth in paragraph 12 of this Declaration.

10. Ownership of Units and appurtenant share in Common Property, Common Surplus and Common Expenses. Each Unit shall be conveyed and treated as an individual property capable of independent use and fee simple ownership, and the owner or owners of each said Unit shall own, as an appurtenance to each Unit, a one fourth fourth (1/44) undivided share of all Common Property and any Common Surplus of the Condominium. Except as otherwise provided in paragraph 12 hereinafter each Unit Owner and each Unit shall be liable for a proportionate share of the Common Expenses according to the undivided share of ownership of Common Property set forth above. Each Unit Owner and Unit shall have a proportionate share in the Common Surplus, such shares bearing the same proportion to the whole as the Unit Owner's undivided ownership of Common Property. These shares shall remain the same regardless of the purchase price of the Unit, its location or size, except as may otherwise be set forth herein.

a. The fee title to each Unit will include the Unit, and its undivided interest in the Common Property, said interests to be deemed to be conveyed or encumbered with each respective Unit, even though the description in the instruments of conveyance or encumbrance may refer only to the fee title to the Unit. Any attempt to separate the fee title to a Unit from the undivided interest in the Common Property appurtenant to such Unit, shall be null and void.

THIS SPACE INTENTIONALLY LEFT BLANK

COPY

b. In the event that any one or more of the Units are not rebuilt by reason of the loss of Condominium Property from destruction, condemnation or otherwise, and, therefore, the number of Units is reduced, or in the event the Association becomes a Unit Owner, then the proportionate share of the Common Expenses and the Common Surplus of each Unit remaining which is not owned by the Association shall be increased to the appropriate fraction having a denominator equal to the number of Units then remaining and which are not owned by the Association and a numerator equal to one (1). Upon the sale of a Unit by the Association a similar adjustment shall be made to appropriately reduce the share of the Common Expenses and Common Surplus of each Unit.

11. Facility Assessment. The Association shall assess each condominium for which it has operating responsibilities, when

COPY

THIS SPACE INTENTIONALLY LEFT BLANK

COPY

COPY

completely constructed, for such condominium's pro-rata share of the cost and expenses of operation, maintenance and/or servicing the River Run Dock Condominium; such pro-rata share to be equivalent to the product of the total cost and expense and a fraction the numerator of which shall be one (1) and the denominator of which shall be the total number of units for which the Association has operating responsibilities; or 44. Such assessed expenses shall be considered a general Common Expense of each such condominium so assessed, if any. That same proportion of assessed expense shall also represent each separate condominium's interest in any Association-owned property, which interest shall be deemed Common Property of each condominium, to be shared by the Unit Owners of each condominium in accordance with such Unit Owners' individual shares in the Common Property of such individual condominium.

13. Restraint upon separation and partition of Common Property. Recognizing that the proper use of a Unit by any Unit Owner is dependent upon the use and enjoyment of the Common Property in common with all other Unit Owners and that it is in the interest of all Unit Owners that the ownership of the Common Property be retained in common by the owners of Units in the Condominium, it is declared that the undivided interest in the Common Property appurtenant to each Unit shall remain undivided and no owner of any Unit shall bring or have any right to bring any action for partition or division.

14. Restriction against further subdividing of Units and separate conveyance of appurtenant Common Property, etc. Except as reserved to Developer, no Unit may be divided or subdivided into a smaller Unit or smaller Units than as shown on Exhibit D hereto, nor shall any Unit, or portion thereof, be added to or incorporated into any other Unit without the prior written consent of the Board of Directors of the Association as hereinbelow provided. The undivided interest in the Common Property

THIS SPACE INTENTIONALLY LEFT BLANK.

declared to be an appurtenance to each Unit shall not be conveyed, devised, encumbered or otherwise dealt with separately from said Unit, and the undivided interest in Common Property appurtenant to each Unit shall be deemed conveyed, devised, encumbered or otherwise included with the Unit even though such undivided interest is not expressly mentioned or described in the instrument conveying, devising, encumbering or otherwise dealing with such Unit. Any conveyance, mortgage or other instrument which purports to affect the interest or lien in, to or upon a Unit shall be null, void and of no effect insofar as the same purports to affect any interest in a Unit and its appurtenant undivided interest in Common Property, unless the same purports to convey, devise, encumber or otherwise trade or deal with the entire Unit. Any instrument conveying, devising, encumbering or otherwise dealing with any Unit which described said Unit by the unit number assigned thereto in Exhibit B without limitation or exception shall be deemed and construed to affect the entire Unit and its appurtenant undivided interest in the Common Property. Nothing herein contained shall be construed as limiting or preventing ownership of any Unit and its appurtenant undivided interest in Common Property by more than one (1) person or entity as tenants in common, joint tenants or as tenants by the entirety.

15. Use or acquisition of interest in the Condominium to render user or acquirer subject to provisions of Declaration of Condominium, rules and regulations. All present or future Unit Owners, tenants or any other person who might use the facilities of the Condominium in any manner are subject to the provisions of this Declaration of Condominium, and to the rules and regulations of the Association, as the same may from time to time be adopted and promulgated, and the mere acquisition or rental of any Unit, or the mere act of occupancy of any Unit, shall signify that the provisions of this Declaration of Condominium and of the Association's rules and regulations are accepted and ratified in all respects.

16. The Association.

a. Administration of the Condominium by the Association. To efficiently and effectively provide for the administration of the Condominium by the Unit Owners, a non-profit Florida corporation, known and designated as "RIVER RUN OF SEBASTIAN CONDOMINIUM ASSOCIATION, INC." has been organized, and said Association shall administer the operation and management of the Condominium, and undertake and perform all acts and duties incident thereto in accordance with the terms, provisions and conditions of this Declaration of Condominium, and in accordance with the terms of the Articles of Incorporation and the By-laws of said Association. A true copy of each of the Articles of Incorporation and By-laws of the Association are annexed hereto and expressly made a part hereof as Exhibits G and H respectively. Each Unit Owner shall automatically become a member of the Association upon his, their or its acquisition of an ownership interest in or title to any Unit in the Condominium, and the appurtenant undivided interest in Common Property in the Condominium, and upon recording evidence of such ownership interest in the public records of Indian River County, Florida; and the membership of such Unit Owner shall terminate automatically upon such Unit Owner being divested of such ownership interest in or title to such Unit, regardless of the means by which such ownership may be divested. No person, firm or corporation holding any lien, mortgage or other encumbrance upon any Unit shall be entitled, by virtue of such lien, mortgage or other encumbrance, to membership in the Association, or to any of the rights or privileges of such membership. In the administration of the operation and management of the Condominium, said Association shall have and is hereby granted the authority and power to enforce the provisions of this Declaration of Condominium, levy and collect assessments in the manner hereinafter provided, and to adopt, promulgate and enforce such rules and regulations governing the use of the Units and Common Property as the Board of Directors of the Association may



deem to be in the best interests of the Condominium.

b. On all matters on which the membership is entitled to vote, there shall be only one (1) vote for each Unit in the Condominium and such vote may be exercised by the Unit Owner in the manner provided in the By-laws of the Association, such vote being subject to any limitations or restrictions provided in said Bylaws or in this Declaration of Condominium. Reference is hereby made to paragraph 32 of this Declaration and provisions therein made relating to the Board of Directors of the Association. Should any member own more than one Unit in the Condominium, such member shall be entitled to exercise as many votes as he owns Units.

c. Modification or Amendment of By-laws. No modification or amendment to the By-laws of the Association shall be valid unless set forth in or annexed to a duly recorded amendment to this Declaration. The By-laws may be amended in the manner provided for therein, but no such amendment shall be adopted, which would affect or impair the validity or priority of the record owner of any mortgage covering any Unit, unless said mortgagee shall join in the execution of the amendment.

d. Limitation upon Liability of the Association. Notwithstanding the duty of the Association to maintain and repair parts of the Condominium Property, the Association shall not be liable to Unit Owners for any injury or damage, other than the cost of maintenance and repair, caused by any latent condition of the property to be maintained and repaired by the Association or caused by the elements or other owners or persons.

e. Restraint upon Assignment of Shares in Assets. The share of a member in the funds and assets of the Association cannot be assigned, hypothecated or transferred, except by sale of the Unit to an owner of a River Run of Sebastian Residential Condominium Unit. No Unit may be sold to any person who is not an owner of a residential Unit in the River Run of Sebastian Condominium.

17. Maintenance, Alteration and Improvement. Responsibility for the maintenance of the Condominium Property and restrictions upon its alteration and improvements shall be as follows:

a. Maintenance and Repair of Common Property and Limited Common Property by Association. The Association, at its expense, shall be responsible for the maintenance, repair and replacement of all of the Common Property and all conduits, ducts, plumbing, wiring and other facilities located in or on the Common Property for the furnishing of utility or drainage services to the Units, the Common Property, and, should any incidental damage be caused to any Unit by virtue of any work which may be done or caused to be done by the Association in the maintenance, repair or replacement of or at any Common Property, the said Association shall, at its expense, repair such incidental damage. If repairs to Common Property, are made necessary by the negligence of any Unit Owner, members of his family, or his guests, employees, agents, invitees or lessees, then such repairs shall be effected by the Association at the expense of said Unit Owner, and payment for the same shall be made within ten (10) business days of delivery or mailing of written demand by the Association; if unpaid within ten (10) business days after delivery or mailing of such written demand, then the Association may proceed to collect the same, together with costs of collection, by filing suit for damages or obtaining injunctive relief or by fine.

b. Right of entry for maintenance of Common Property. Whenever it is necessary to enter any Unit for the purpose of performing any maintenance, alteration or repair to any portion of the Common Property, property owned by the Association, or other property for which the Association has operating responsibilities, each Unit Owner shall permit other Unit Owners or their representatives, or the duly constituted and authorized agent of the Association, to enter such Unit, for such purpose, provided that such entry shall be made only at reasonable times and with reasonable advance notice.

18. Assessments: Liability, lien and enforcement. The Association is given the authority to administer the operation and management of the Condominium, it being recognized that the delegation of such duties to one entity is in the best interests of all Unit Owners. To properly administer the operation and management of the Condominium, the Association will incur, for the mutual benefit of all Unit Owners, costs and expenses which will be continuing or non-recurring costs, as the case may be, which costs and expenses are herein referred to as "Common Expenses". To provide the funds necessary for such proper operation and management, the said Association has heretofore been granted the right to make, levy and collect assessments against all Unit Owners and against the said Units. In furtherance of said grant of authority to the Association to make, levy and collect assessments to pay the costs and expenses for the operation and management of this Condominium, the following provisions shall be operative and binding upon all Unit Owners, to-wit:

a. The Board of Directors of the Association shall establish an annual budget for each condominium for which it has operating responsibilities and for the Association itself in advance of each fiscal year to project and determine the amount of the Common Expenses which may be required for the proper operation, management and maintenance of each condominium and to allocate and assess such Common Expenses among the Unit Owners of

THIS SPACE INTENTIONALLY LEFT BLANK

COPY

each separate condominium according to the share that each is required to pay. In determining such Common Expenses, the Board of Directors may provide for an operating reserve not to exceed fifteen (15%) percent of the total projected Common Expenses for the year. Unless the Unit Owners of each separate condominium determine, by a majority of those Unit Owners of each separate condominium present at a meeting of the members to provide no reserves or reserves less adequate than required by law, the Board of Directors, in addition to annual operating expenses, shall include in each separate condominium budget reserve accounts for capital expenditures and deferred maintenance computed by means of a formula which is based upon estimated life and estimated replacement cost of each reserve item. Each Unit Owner shall be liable for the payment to the Association of that proportion of the Common Expenses as determined in each said budget, as each Unit shares in the Common Property as hereinabove set forth in paragraphs 10 and 12; provided, however, that the Developer shall be excused from the payment of the share of the Common Expenses and assessments related to unsold Units in the Condominium from January 1, 1987, through December 31, 1988, or until Developer has transferred control of River Run of Sebastian Condominium Association, Inc., whichever shall first occur, during which period of time Developer has guaranteed that each Unit Owner other than Developer shall be required to pay no more than \$18.18 per month for Common Expenses for each Unit so owned, including Association budget charges, and Developer hereby obligates itself to pay any amount of Common Expenses during said period which has not been billed by assessments against Unit Owners other than Developer. Through December 31, 1988, Developer shall not be assessed for or pay any Common Expenses for any Unit owned by it except as herein provided.

b. Special assessments may be made by the Board of Directors from time to time to meet other needs or requirements of the Association in the operation and management of the Condominium or the Additional Facilities and to provide for emergencies, repairs or replacements, and infrequently recurring items of maintenance, or to perform any other function or act authorized expressly or impliedly by this Declaration, the Articles of Incorporation of the Association or its By-laws.

c. All monies collected by the Association shall be treated as the separate property of the said Association, and such monies may be applied by the said Association to the payment of any expense of operating and managing the Condominium, the Condominium Property or the Additional Facilities, undertaking all acts and duties imposed upon it by virtue of this Declaration of Condominium and the Articles of Incorporation and By-laws of the Association, and, as the monies for any assessment are paid unto the Association by a Unit Owner, the same may be commingled with the monies paid to the said Association by other Unit Owners. Although all funds and other assets of the Association, and increments thereto or profits derived therefrom, or from the leasing or use of Common Property, shall be held for the benefit of the members of the Association, no member of said Association shall have the right to assign, hypothecate, pledge or in any manner transfer his membership interest therein, except as an appurtenance to his Unit. When a Unit Owner shall cease to be a member of Association by reason of the divestment of his ownership of such Unit, by whatever means, the Association shall not be required to account to such Unit Owner for any share of the funds or assets of Association, or which may have been paid to said Association by such Unit Owner, as all monies which any Unit Owner has paid to the Association shall be and constitute an asset of said Association which may be used in the operation and management of this Condominium.

d. The liability for any assessment or portion thereof may not be avoided by a Unit Owner or waived by reason of such Unit Owner's waiver of the use and enjoyment of any of the Common Property or Additional Facilities or by his abandonment of his Unit.

e. Any assessment or installment thereon not paid within ten (10) business days from the date upon which it is due shall be deemed delinquent and shall bear interest thereon at the highest rate then allowed by the laws of the State of Florida from its due date and shall remain delinquent until fully paid, together with accrued interest. All payments upon account will be first applied to interest and then to the assessment payment first due. If such delinquency is not made good within sixty (60) calendar days from the date the same occurred, the balance of the annual assessment remaining unpaid shall become immediately due and payable, and the Association may proceed to collect the same in any manner provided by law, including, without limitation, the foreclosure of its lien as provided in the Condominium Act.

f. The provisions of Section 718.116 of the Florida Condominium Act in effect at the time of recording this Declaration, where the same are not in conflict with other provisions of this section of this Declaration, are incorporated herein by reference and made a part hereof.

g. The lien provided for in such Section 718.116 of the Florida Statutes shall also secure reasonable attorney's fees and costs incurred by the Association incident to the collection of assessments or enforcement of the lien therefor, as well as any sums expended by the Association to protect the security of its lien.

h. The holder of a first mortgage acquiring title to a Unit by a purchase at the public sale resulting from the first mortgagee's foreclosure judgment in a foreclosure suit in which the Association has been properly named as a defendant junior lienholder or by acceptance of a voluntary conveyance in lieu thereof, or a purchaser at a judicial sale resulting from the foreclosure of a first mortgage, and their successors and assigns, shall not be liable for the share of Common Expenses or assessments pertaining to such Unit or chargeable to the former Unit Owner, which become due prior to such acquisition of title unless the share is secured by a claim of lien for assessments that is recorded prior to the recording of the foreclosed mortgage. Such unpaid share of Common Expenses shall be collectible from all members of the Association and from all those who are Unit Owners in this Condominium at the time of such acquisition of title including such acquirer of title. Should the Association be the owner of any Unit or Units, the assessment which would otherwise be due and payable to the Association by the owner of such Unit or Units, reduced by the amount of income which may be derived from the leasing of such Unit or Units by Association, shall be apportioned and assessment therefor levied ratably among all Unit Owners based upon their proportionate ownership of Units exclusive of the Units owned by the Association.

i. In any voluntary conveyance of a Unit, the grantee shall be jointly and severally liable with the grantor for all unpaid assessments against grantor made prior to the time of transfer of title, without prejudice to the rights of the grantee to recover from the grantor the amounts paid by the grantee therefor.

j. Institution of a suit at law to attempt to effect collection of the payment of any delinquent assessment shall not be deemed to be an election by the Association which shall prevent its thereafter seeking collection of any sums remaining owing to it by foreclosure, nor shall proceeding by foreclosure to attempt to effect such collection be deemed to be an election precluding the institution of suit at law to attempt to effect collection of any sum then remaining owing to it.

19. Right of the Association to alter and improve property and make assessment therefor. The Association shall have the right to make or cause to be made such alterations or improvements to the Common Property as do not prejudice the rights of any Unit Owner in the use and enjoyment of his Unit, (unless such

Unit Owner's written consent has been previously obtained), provided the making of such alterations and improvements is approved by the Board of Directors of said Association, and the cost of such alterations or improvements shall be Common Expenses to be assessed and collected from all Unit Owners. The cost of such alterations or improvements shall not be assessed against an institutional lender acquiring its title as the result of owning a mortgage upon a Unit, unless such institutional lender shall approve the alterations or improvements, regardless of whether title was acquired by foreclosure or deed in lieu thereof.

20. Insurance coverage, use and distribution of proceeds, repair or reconstruction after casualty.

a. All insurance policies upon the Condominium Property shall be purchased by the Association. The named insured shall be the Association individually and as agent for the Unit Owners, without naming them, as their interest may appear. Provision shall be made for the issuance of mortgagee endorsements and/or memoranda of insurance to the Unit Owners and their mortgagees.

b. The Association shall be required to obtain and maintain casualty insurance covering all improvements upon the land, including any Additional Facilities, all parts of all docks, walkways, dolphins and fixtures, as are ordinarily covered by similar types of insurance policies, in an amount equal to the maximum insurable replacement value, exclusive of foundation and excavation costs, as determined annually by the insurance carrier; or, if approved by the Board of Directors, such insurance may be carried on not less than an eighty percent (80%) co-insurance basis. The coverage shall afford protection against loss or damage by fire, windstorm and other hazards covered by a standard extended coverage endorsement, and such other risks as shall be customarily covered with respect to docks and walkways similar in construction, location and use, including but not limited to vandalism, malicious mischief and flooding. The Association shall also be required to carry public liability insurance in amount sufficient to provide adequate protection to the Association and its members. All liability insurance maintained by the Association shall contain cross-liability endorsements to cover liability of the Unit Owners as a group to each Unit Owner.

c. The Association may carry such other insurance, or obtain such other coverage, as the Board of Directors may determine to be desirable. Employer's liability insurance shall be obtained if necessary to comply with the Workmen's Compensation Law.

d. The premiums upon all insurance policies shall be paid by the Association as a Common Expense.

e. The Association is hereby declared to be and appointed as authorized agent for all Unit Owners for the purpose of negotiating and agreeing to a settlement as to the value and extent of any loss which may be covered under any policy of casualty insurance, and is granted full right and authority to execute in favor of any insurer a release of liability arising out of any occurrence covered by any policy or policies of casualty insurance and resulting in loss or damage to insured property.

f. Any proceeds becoming due under the casualty insurance policy or policies for loss, damage or destruction sustained to the Condominium Property or Additional Facilities shall be payable to the Association and the institutional first mortgagees to which have been issued loss payable mortgagee endorsements.

g. In the event any loss, damage or destruction to the insured premises is not substantial (as such term "substantial"

is hereinafter defined), and such loss, damage or destruction is replaced, repaired or restored with the Association's funds, the institutional first mortgagees which are named as payees upon the drafts issued by the insurance carrier shall endorse said drafts and deliver the same to the Association; provided, however, that any repair and restoration on account of physical damage shall restore the improvements to substantially the same condition as existed prior to the casualty.

h. "Substantial" loss, damage or destruction, as the term is used herein, shall mean any loss, damage or destruction sustained to the insured improvements which would require an expenditure of sums in excess of five percent (5%) of the amount of coverage applicable to the particular improvement or improvements suffering loss, damage or destruction in any one instance under the Association's casualty insurance policy or policies then existing, in order to restore, repair and reconstruct the loss, damage or destruction sustained.

i. Any casualty insurance proceeds becoming due by reason of substantial loss, damage or destruction sustained to the Condominium Property shall be payable to the Association, unless there shall have been issued a loss payable mortgagee endorsement to an institutional first mortgagee, in which case insurance proceeds shall be made available to the institutional first mortgagee which shall hold the mortgage on the particular improvement sustaining loss, damage or destruction, or, in the event of loss, damage or destruction to more than one Unit, to the institutional first mortgagee which may hold the mortgage or mortgages encumbering the greatest number of Units which may have sustained loss, damage or destruction in any one instance in the Condominium, which proceeds shall be held in a construction fund to provide for the payment of all work, labor and materials to be furnished for the reconstruction, restoration and repair of the Condominium Property. Disbursements from such construction fund by such institutional first mortgagee shall be in accordance with such institution's usual and customary construction loan procedures. In the event of the loss of or damage to Common Property, Additional Facilities and any Unit or Units, which loss or damage is covered by the casualty insurance, the proceeds paid to the Association to cover such loss or damage shall be first applied to the repair, replacement or reconstruction, as the case may be, of Common Property, real or personal, Additional Facilities and then any remaining insurance proceeds shall be applied to the repair, replacement or reconstruction of any Unit or Units which may have sustained loss or damage so covered. Any sums remaining in the construction fund after the completion of the restoration, reconstruction and repair of the improvements and full payment therefor shall be paid over to the Association and held for, and/or distributed to, the Unit Owners in proportion to each Unit Owner's share of the Common Surplus. If the insurance proceeds payable as a result of such casualty are not sufficient to pay the estimated costs of such restoration, repair and reconstruction, which estimate shall be made prior to proceeding with restoration, repair or reconstruction, the Association shall levy a special assessment against the owner of each damaged unit and against all members and all Unit Owners (as a Common Expense) in case of damage to Common Property or Additional Facilities, for the amount of such insufficiency, and shall pay said sum into the aforesaid construction fund. If at any time during reconstruction and repair or upon completion of reconstruction and repair the funds in the hands of Association for the payment of the costs thereof are insufficient, assessments shall be made against the owners who own the damaged Units, and against all Unit Owners in the case of damage to Common Property or Additional Facilities, in sufficient amounts to provide funds for the payment of such costs. Such assessments against Unit Owners for damage to Units shall be in proportion to the cost of reconstruction and repair of their respective Units.

j. Notwithstanding which institutional first mortgagee holds the mortgage or mortgages encumbering the greatest number of Units,

such mortgagees may agree between or among themselves as to which one shall administer the construction fund in the event of loss or damage to more than one Unit in any one instance. If there be no institutional mortgagee as to whom a loss payable endorsement has been issued for any Unit, then the insurance proceeds for loss or damage to such unencumbered Unit shall be paid to the Association and used for reconstruction and repair in the same manner hereinabove provided for use by an institutional first mortgagee.

k. If the damage sustained to the improvements is less than substantial, as heretofore defined, the Board of Directors may determine that it is in the best interests of the Association to pay the insurance proceeds into a construction fund to be administered by an institutional first mortgagee as hereinabove provided. No institutional mortgagee shall be required to cause such insurance proceeds to be made available to the Association prior to completion of any necessary restoration, repair or reconstruction, unless arrangements are made by the Association to satisfactorily assure that such restoration, repair and reconstruction shall be completed. Such assurances may consist of, without limitation, obtaining (1) a construction loan from other sources, (2) a binding contract with a contractor or contractors to perform the necessary restoration, repair and reconstruction, or (3) the furnishing of performance and payment bonds.

l. Any restoration, repair or reconstruction made necessary through a casualty shall be commenced and completed as expeditiously as reasonably possible, and must substantially be in accordance with the plans and specifications for the construction of the original building. In no event shall any reconstruction or repair change the relative locations and approximate dimensions of the Common Property or of any Unit, unless an appropriate amendment be made to this Declaration.

m. Where physical damage has been sustained to the Condominium Property and the insurance proceeds have not been paid into a construction fund as hereinabove more fully provided, and where restoration, repair or reconstruction has not been commenced, an institutional mortgagee who has commenced foreclosure proceedings upon a mortgage encumbering a Unit which shall have sustained loss, damage or destruction shall be entitled to receive that portion of the insurance proceeds applicable to the loss sustained by said Unit provided that no other Unit, Common Property, or Additional Facilities shall have sustained loss, damage or destruction occasioned at the same time and from the same cause (in which event said institutional mortgagee shall only be entitled to receive the portion of the insurance proceeds apportioned to said Unit in the same share as the share in the Common Property appurtenant to said Unit).

n. If substantial loss, damage or destruction shall be sustained to the Condominium Property, a majority of the Board of Directors of Association, at a special meeting called for such purpose, may vote that the damaged property will not be repaired or reconstructed, and may further vote to terminate the Condominium, provided, however, such termination will not be effective without the written consent of all institutional first mortgagees holding mortgages encumbering Units. See paragraph 37 concerning termination of the Condominium.

21. Personal liability and risk of loss of Unit Owners and separate insurance coverage, etc. Each Unit Owner may, at his own expense, obtain insurance coverage for loss of or damage to any personal property belonging to such Unit Owner, and may, at his own expense and option, obtain insurance coverage against personal liability for injury to the person or property of another while within such owner's Unit or upon the Common Property, or Additional Facilities. All such insurance obtained by any Unit Owner shall, wherever such provision is available, provide that the insurer waives its right of

subrogation as to any claims against other Unit Owners, the Association and the respective servants, agents or guests of other Unit Owners and the Association, and such other insurance coverage shall be obtained from the insurance company from which Association obtains coverage. Risk of loss or damage to any personal effects and other personal property belonging to or carried on the person of any Unit Owner, or which may be stored in any Unit, or in, to or upon Common Property or Additional Facilities, shall be borne by each such Unit Owner. All personal property and furnishings or fixtures constituting a portion of the Common Property or Additional Facilities and held for the joint use and benefit of all Unit Owners shall be covered by such insurance as shall be maintained in force and effect by the Association as herein provided. No Unit Owner shall have any personal liability for any damages caused by the Association or in connection with the use of the Common Property or Additional Facilities. A Unit Owner shall be liable for injuries or damages resulting from an accident in his own Unit, to the same extent and degree that the owner of a house would be liable for an accident occurring within his house.

22. Right of entry into Units in emergencies. In case of any emergency originating in or threatening any Unit, regardless of whether the owner is present at the time of such emergency, the Board of Directors of the Association, or any other person authorized by it, or the building superintendent or managing agent, shall have the right to enter such Unit for the purpose of remedying or abating the cause of such emergency, and such right of entry shall be immediate, and, to facilitate entry in the event of any such emergency, each Unit Owner, if required by the Association, shall deposit with the Association, and under the control of the Association, a key to his personal property.

23. Limitation upon right of owners to alter and modify Units. No Unit Owner shall permit the making of any structural modifications or alterations in his Unit without first obtaining the written consent of the Association, which consent may be withheld in the event that a majority of the Board of Directors of the Association determine, in their sole and absolute discretion, that such structural modifications or alterations would affect or in any manner endanger the Condominium in part or in its entirety. No Unit Owner shall cause any improvements or changes to be made on the exterior of his Unit or of the Condominium, including painting or other decoration, or the installation of electrical wiring, television antennas, machines or air conditioning units, or in any manner change the appearance of any portion of the Unit. No Unit Owner will cause anything to be hung, displayed or placed on the docks and walkways, and no Unit Owner will in any way change or alter the appearance of any portion of the exterior of the Condominium Units without the prior, written consent of the Association. No signs of any type other than those required by law, will be allowed on any part of the Condominium.

The Association shall determine the exterior color scheme of the Condominium and the nature and color of all exterior decorative elements, fixtures or furnishings.



24. Use restrictions, use of Common Property, and Additional Facilities subject to rules of the Association. Each Unit is hereby restricted to use as a docking facility for one boat. No boat may be used as a live-aboard boat while occupying Condominium space, and the use of Common Property, and Additional Facilities by any Unit Owner and all other parties authorized or entitled to use the same, shall be at all times subject to such reasonable rules and regulations as may be prescribed and established by the Association.

a. No animals or pets of any kind shall be kept in any Unit, on the property of the Condominium or in or on any Additional Facility except with the written consent of the Board of Directors of the Association and thereafter under the rules and regulations adopted by such Board; provided that such consent will not be given to permit such animals or pets to be kept, bred or maintained for any commercial purpose and further provided that any permitted pet causing or creating a nuisance or unreasonable disturbance shall be permanently removed from the Condominium Property or Additional Facilities upon three (3) days written notice from said Board.

b. No vehicles or objects, including but not limited to trucks, motorcycles, motor homes and trailers, may be placed or parked upon any portions of the Condominium Property or Additional Facilities unless permitted by said Board.

c. After approval by the Board of Directors of the Association as elsewhere required, entire Units may be rented to other residents or owners of Condominiums within the River Run Condominium project, provided the use is only by the Lessee, or by family or social guests of the Lessee. All leases must be for a minimum term of at least ninety (90) days.

d. Until the Developer has closed sales of all of the Units in this Condominium and other condominiums for which the Association has operating responsibilities, neither the Unit Owners nor the Association shall interfere with the sale of such Units. The Developer may make such use of the unsold Units, Common Property and Additional Facilities as may facilitate sales, including but not limited to maintenance of a sales office, model Units, the showing of the property and the display of signs.

25. The Condominium to be used for lawful purposes, restriction against nuisances, etc. No immoral, improper, offensive or unlawful use shall be made of any Unit or of the Common Property, the or any Additional Facilities, nor any part thereof, and all rules and regulations, all laws, zoning ordinances and regulations of all governmental authorities having jurisdiction over the Condominium shall be observed by all Unit Owners and others present on Condominium Property and Additional Facilities. No Unit Owner shall permit or suffer anything to be done or kept in his Unit or on the Common Property, or any Additional Facilities, which will increase the rate of insurance on the Condominium or which will obstruct or interfere with the rights of other Unit Owners or annoy them by unreasonable noises, nor shall any such Unit Owner undertake any use or practice which shall create or constitute a nuisance to any other Unit Owner, or which interferes with the peaceful possession and proper use of

any other Unit, the Common Property, or any Additional Facilities.

26. Sales of Units. Ownership of units is restricted solely to owners of dwelling units in River Run Condominiums A, B, C, D, and E. Units are to be used only for the owner's boat and are not to be leased to or used by others, except that the lessee of an owner's apartment may be granted the right to use the unit during the term of his apartment lease. If the owner's apartment is sold, transferred, or foreclosed the unit must either be sold to the new owner, to another owner of an apartment in River Run Condominium A, B, C, D, and E, or to the River Run Condominium Association. No owner of an apartment in River Run Condominium A, B, C, D, and E may own more than one unit per apartment owned.

27. Transfers other than by sale.

a. If any Unit Owner shall acquire his title by gift, the continuance of his ownership of his Unit will be subject to the approval of the Board of Directors of the Association.

b. If any Unit Owner shall acquire his title by devise or inheritance, the continuance of his ownership of his Unit will be subject to the approval of the Board of Directors of the Association.

c. If any Unit Owner shall acquire his title by any manner not considered in the foregoing subsections or in paragraph 26, the continuance of his ownership of his Unit will be subject to the approval of the Board of Directors of the Association.

d. A Unit Owner who has obtained his title by gift, devise or inheritance, or by any other manner not previously considered, shall give to the Board of Directors of the Association notice of the acquiring of his title, together with such information concerning such Unit Owner as said Board may reasonably require and a certified copy of the instrument evidencing the Unit Owner's title. If the above required notice to the Board of Directors of the Association is not given, then, at any time after receiving knowledge of a transaction or event transferring ownership or possession of a Unit, said Board, at its election and without notice may approve or disapprove the transaction or ownership. If said Board disapproves the transaction or ownership, it will proceed as if it had received the required notice on the date of such disapproval.

e. If the Unit Owner giving notice has acquired his title by gift, devise or inheritance, or in any other manner not previously mentioned, within sixty (60) days after receipt from the Unit Owner of the notice and information required to be furnished, the Board of Directors, if it shall affirmatively disapprove such ownership, may deliver or mail by registered mail to the Unit Owner an agreement to purchase the Unit concerned by a purchaser approved by it, who will purchase and to whom the Unit Owner must sell the Unit under the following terms:

(1) The sale price will be the fair market value determined by agreement between the seller and purchaser within thirty (30) days from the delivery or mailing of such agreement. In the absence of agreement as to price, the price will be determined by arbitration in accordance with the then existing rules of the American Arbitration Association, except that the arbitrators will be two (2) appraisers appointed by the American Arbitration Association who will base their determination upon an average of their appraisals of the Unit; and a judgment of specific performance of the sale upon the award rendered by the arbitrators may be entered in any court of competent jurisdiction. The expense of the arbitration will be paid by the purchaser.

(2) The purchase price will be paid in cash.

(3) The sale will be closed within twenty (20) days following the determination of the sale price.

(4) A certificate approving the purchaser will be executed by the President and Secretary of the Association.

(5) If the Board of Directors of the Association shall fail to provide a purchaser as required by this instrument, or if a purchaser furnished by the Association shall default in his agreement to purchase, then, notwithstanding the disapproval, such ownership will be deemed to have been approved, and said Board shall furnish a certificate of approval as elsewhere provided.

f. No provision or limitation hereinabove provided in this paragraph 27 shall be applicable or operative as to any transfer by Developer.

28. Association to maintain registry of Unit Own. The Association shall at all times maintain a register setting forth the names of all Unit Owners, and, in the event of the sale or transfer of any Unit to a third party, the purchaser or transferee shall notify the Association in writing of his interest in such Unit together with such recording information as shall be pertinent to identify the instrument by which such purchaser or transferee has acquired his interest in any Unit.

29. No Mortgages may be placed upon Units.

30. Apportionment of tax or special assessment if levied and assessed against the Condominium as a whole. In the event that any taxing authority having jurisdiction over the Condominium shall levy or assess any tax or special assessment against the Condominium as a whole, as opposed to levying and assessing such tax or special assessment against each Unit and its appurtenant undivided interest in Common Property and Limited Common Property, as now provided by law, then such tax or special assessment so levied shall be paid as a Common Expense by the Association, and any taxes or special assessments which are to be so levied shall be included, wherever possible, in the estimated annual budget of the Association, or shall be separately levied and collected as an assessment by the Association against all Unit Owners and said Units if not included in said annual budget. The amount of any tax or special assessment paid or to be paid by the Association in the event that such tax or special assessment is levied against the Condominium as a whole, instead of against each separate Unit and its appurtenant and undivided interest in Common Property and Limited Common Property shall be apportioned among the owners of all Units so that the amount of tax or special assessment so paid or to be paid by the Association and attributable to and to be paid by each Unit Owner shall be that portion of such total tax or special assessment which bears the same ratio to said total tax or special assessment as the undivided interest in Common Property appurtenant to each Unit bears to the total undivided interest in Common Property appurtenant to all Units. In the event that any tax or special assessment shall be levied against the Condominium in its entirety, without apportionment by the taxing authority to the Units and appurtenant undivided interests in Common Property, then the assessment by Association, which shall include the proportionate share of such tax or special assessment attributable to each Unit and its appurtenant undivided interest in Common Property, shall separately specify and identify the amount of such assessment attributable to tax or special assessment, and the amount of such tax or special assessment so designated shall be and constitute a lien prior to all mortgages and encumbrances upon any Unit and its appurtenant undivided interest in Common Property regardless of the date of the attachment or recording of such mortgage or encumbrance, to the same extent as though such tax or special assessment had been separately levied by the taxing authority upon each Unit and its appurtenant undivided interest in Common Property.

All personal property taxes levied or assessed against personal property owned by the Association shall be paid by said Association and shall be included as a Common Expense in the annual budget of the Association.

31. Right of Developer to sell or lease Units owned by it free of right of first refusal or right of redemption, and right of Developer to representation on Board of Directors of Association. So long as Developer shall own any Unit in any of the Condominiums to be operated by the Association, the said Developer shall have the absolute right to lease or sell any such Unit to any person, firm or corporation upon any terms and conditions as it shall deem to be in its own best interests. However, the developer and its designees shall have the right to be exempt from any such parking restriction if the vehicle is engaged in any activity relating to construction, maintenance, or marketing of units, if such exemption is provided in the condominium documents.

a. When Unit Owners other than the Developer own fifteen percent (15%) or more of any single condominium that will be operated ultimately by the Association, the Unit Owners other than the Developer shall be entitled to elect not less than one-third (1/3) of the members of the Board of Directors of the Association. Unit Owners other than the Developer shall be entitled to elect not less than a majority of the members of the Board of Directors of the Association three (3) years after sales by the Developer have been closed of fifty percent (50%) of the Units that will be operated ultimately by the Association, three (3) months after sales have been closed by the Developer of ninety percent (90%) of the Units that will be operated ultimately by the Association, or when all of the Units that will be operated ultimately by the Association have been completed, some of them have been sold, and none of the others are being offered for sale by the Developer in the ordinary course of business, whichever shall first occur. The Developer shall be entitled to elect not less than one member of the Board of Directors of the Association as long as the Developer holds for sale in the ordinary course of business five percent (5%) of the Units in any single condominium that will be operated by the Association. Whenever Developer shall be entitled to designate and select any person or persons to serve on any Board of Directors of the Association, the manner in which such person or persons shall be designated shall be as provided in the Articles of Incorporation or By-laws of the Association, and Developer, or Developer's successors or assigns, shall have the right to remove any person or persons selected by it to act and serve on said Board of Directors and to replace such person or persons with another person or persons to act and serve in the place of any director or directors so removed for the remainder of the unexpired term of any director or directors so removed. Any director designated and selected by Developer need not be a resident in the Condominium or a member of the Association.

b. Any representative or designee of Developer serving on the Board of Directors of the Association shall not be required to disqualify himself upon any vote upon any management contract or any other matter between Developer and the Association in which the said Developer may have a pecuniary or other interest. Similarly, Developer, as a member of the Association, shall not be required to disqualify itself in any vote which may come before the membership of the Association upon any management contract or any other matter between Developer and the Association in which the said Developer may have a pecuniary or other interest.

**32. Remedies in event of default.** All Unit Owners shall be governed by and shall comply with the provisions of this Declaration of Condominium and the Articles of Incorporation, By-laws and rules and regulations of the Association, as any of the same are now constituted or as they may hereafter be amended or adopted from time to time. A default by any Unit Owner shall entitle the Association or any other Unit Owner to the following relief:

a. Failure to comply with any of the terms of this Declaration of Condominium or other restrictions and regulations contained in the Articles of Incorporation or By-laws of the Association, or which may be adopted pursuant thereto, shall be grounds for relief which may include, without intending to limit the same, an action to recover sums due for damages, injunctive relief, foreclosure of lien or any combination thereof, and which relief may be sought by the Association, or, if appropriate, by an aggrieved Unit Owner.

b. Each Unit Owner shall be liable for the expense of any maintenance, repair or replacement rendered necessary by his act, neglect or carelessness, or by that of any member of his family, or his or their guests, employees, agents or lessees, but only to the extent that such expense is not met by the proceeds of insurance carried by the Association. Such liability shall include any increase in fire insurance rates occasioned by use, misuse, occupancy or abandonment of a Unit or its appurtenances. Nothing herein contained, however, shall be construed so as to modify any waiver by insurance companies of rights to subrogation. A Unit Owner will pay the Association the amount of any increase in its insurance premiums occasioned by use, misuse, occupancy or abandonment of his Unit or its appurtenances, or of the Common Property or Additional Facilities, by the Unit Owner or any member of his family, or his or their guests, employees, agents or lessees.

c. In any proceeding arising out of an alleged default by any Unit Owner, the Association, if successful, shall be entitled to recover from such Unit Owner the costs of the proceeding, and such reasonable attorney's fees as may be determined by the court.

d. The failure of the Association or of a Unit Owner to enforce any right, provision, covenant or condition which may be granted by this Declaration of Condominium or other above-mentioned documents shall not constitute a waiver of the right of the Association or of a Unit Owner to enforce such right, provision, covenant or condition in the future.

e. All rights, remedies and privileges granted to the Association or any Unit Owner pursuant to any terms, provisions, covenants or conditions of this Declaration of Condominium or other above-mentioned documents shall be deemed to be cumulative, and the exercise of any one or more shall not be deemed to constitute an election of remedies, nor shall it preclude the party thus exercising the same from exercising such other and additional rights, remedies or privileges as may be available to such party at law or in equity.

f. A Unit Owner shall give notice to the Association of every lien, other than for permitted mortgages, taxes and special assessments, and of every suit or other proceeding which may affect title to his Unit within ten (10) calendar days after such Unit Owner receives knowledge thereof.

g. The Association shall give notice to all Unit Owners who may be exposed to liability within a reasonable time of any legal action in which the Association may be exposed to liability in excess of insurance coverage protecting it and Unit Owners, and such Unit Owners shall have such rights as are provided by law to intervene in and defend any such action.

b. The failure of Developer to enforce any right, privilege, covenant or condition which may be granted to it by this Declaration of Condominium or other above-mentioned documents shall not constitute a waiver of the right of Developer to thereafter enforce such right, provision, covenant or condition in the future.

33. Declaration of Condominium binding upon Developer, its successors and assigns, and subsequent Unit Owners. The restrictions and burdens imposed by the covenants of this Declaration of Condominium are intended to and shall constitute covenants running with the land, and shall constitute equitable servitudes upon each Unit and its appurtenant undivided interest in Common Property, and this Declaration of Condominium shall be binding upon and inure to the benefit of Developer, its successors and assigns, and upon all parties who may subsequently become Unit Owners, and their respective heirs, legal representatives, successors and assigns.

34. Liberal construction. The provisions of this Declaration of Condominium shall be liberally construed to effectuate its purpose of creating a uniform plan of condominium ownership.

35. Severability. In the event that any of the terms, provisions or covenants of this Declaration of Condominium are held to be partially or wholly invalid or unenforceable for any reason whatsoever, such holding shall not affect, alter, modify or impair in any manner whatsoever any of the other terms, provisions or covenants hereof or the remaining portions of any terms, provisions or covenants held to be partially invalid or unenforceable.

36. Termination. Notwithstanding anything to the contrary contained in paragraph 20 hereof, in the event of fire or other casualty or disaster which shall so destroy the Condominium building as to require more than two-thirds (2/3) of all Units, as determined by the Board of Directors of Association, in its sole and absolute discretion, to be reconstructed, then this Declaration of Condominium and the plan of condominium ownership established herein shall terminate, unless Unit Owners to which at least seventy-five percent (75%) of the Common Property is appurtenant agree that the condominium shall be reconstructed, or unless any policy or policies of casualty insurance which may cover the damage or destruction of said building requires the reconstruction thereof as a condition precedent to the payment of insurance proceeds under such policy or policies. If, as above provided, this Declaration of Condominium and the plan of condominium ownership established herein is to be terminated, then a certificate of a resolution of the Board of Directors of the Association to said effect and notice of the cancellation and termination hereof shall be executed by the President and Secretary of the Association in recordable form, and such instrument shall be recorded in the public records of Indian River County, Florida. Upon termination of this Declaration of Condominium and the plan of condominium ownership established herein, all of the Unit Owners shall be and become tenants in common as to the ownership of the real property herein described, and any then remaining improvements thereon, the undivided interest in such real property and remaining improvements held by any Unit Owner to be the same as the divided interest in Common Property which was formerly appurtenant to such Unit Owner's Unit and the lien of any mortgage or other encumbrance upon each Unit shall attach, in the same order of priority, to the percentage of undivided interest of a Unit Owner in the Condominium Property and the then remaining improvements as above provided. Upon termination of this Declaration of Condominium and the plan of condominium ownership established herein, the Association shall distribute any insurance indemnity which may be due under any policy or policies of casualty insurance to the Unit Owners and their mortgagees, as their respective interests may appear, such distribution to be made to each Unit Owner in accordance with his then undivided interest in the Condominium Property as hereinbefore provided. The assets of the Association, upon

termination of the plan of condominium ownership created hereby, shall then be distributed to all Unit Owners and to their mortgagees, as their respective interests may appear, in the same manner as was above provided for the distribution of any final insurance indemnity.

a. Except in the event of this Declaration of Condominium and the plan of condominium ownership established herein being terminated as hereinbefore provided, this Declaration of Condominium and said plan of condominium ownership may only be otherwise terminated by the unanimous consent of all Unit Owners and all of the parties holding mortgages, liens or other encumbrances and by the Board of Directors of the Association, in which event the termination of the Condominium shall be by such plan as may then be adopted by said Unit Owners and parties holding any mortgages, liens or other encumbrances and by the Board of Directors of the Association. Such election to terminate this Declaration of Condominium and the plan of condominium ownership established herein shall be executed in writing by all of the aforementioned parties, and such instrument or instruments shall be recorded in the public records of Indian River County, Florida.

37. Amendment of Declaration of Condominium. Except for alteration in the percentage of ownership in Common Property appurtenant to each Unit, or alteration of the basis for apportionment of assessments which may be levied by Association in accordance with the provisions hereof, in which said instances consent of all Unit Owners and their respective mortgagees shall be required and except for any alteration, amendment or modification of the rights and privileges granted and reserved hereunder in favor of Developer, which said rights and privileges granted and reserved unto the said Developer shall only be altered, amended or modified with the express written consent of said Developer, and provided that no amendment to this Declaration shall be adopted which would operate to affect the validity or priority of any mortgage held by an institutional first mortgagee or which would alter, amend or modify, in any manner whatsoever, the rights, powers and privileges granted and reserved herein in favor of any institutional first mortgagee or in favor of the Developer without the consent of all such mortgagees, this Declaration of Condominium may be amended in the following manner:

a. An amendment or amendments to this Declaration of Condominium may be proposed by the Board of Directors of the Association acting upon a vote of the majority of the Directors or by members of the Association owning a majority of the Units in the Condominium, whether meeting as members or by instrument in writing signed by them. Upon any amendment or amendments to this Declaration of Condominium being proposed by said Board of Directors or members, such proposed amendment or amendments shall be transmitted to the President of the Association, who shall thereupon call a special meeting of the members of the Association for a date not sooner than twenty (20) days nor later than sixty (60) days from receipt by him of the proposed amendment or amendments, and it shall be the duty of the Secretary to give to each member written or printed notice of such special meeting, stating the time and place thereof, and reciting the proposed amendment or amendments in reasonably detailed form, which notice is to be mailed not less than fourteen (14) days nor more than thirty (30) days before the date set for such special meeting. If mailed, such notice shall be deemed to be properly given when deposited in the United States mail addressed to a member at his post office address as it appears on the records of the Association, the postage thereon prepaid. Any member may, by written waiver of notice signed by such member, waive such notice and such waiver, when filed in the records of the Association, whether before or after the holding of the meeting, shall be deemed equivalent to the giving of such notice to such member. At such meeting, the amendment or amendments proposed must be approved by an affirmative vote of the members owning Units in this individual Condominium as to which at least fifty-one

percent (51%) of the Common Property is appurtenant in order for such amendment or amendments to become effective unless otherwise expressly required by Florida law. Thereupon, such amendment or amendments of this Declaration of Condominium shall be transcribed and certified by the President and Secretary of Association with the same formalities as a deed and shall be recorded in the public records of Indian River County, Florida within twenty (20) days from the date on which the same became effective, such amendment or amendments to specifically refer to the recording data identifying the Declaration of Condominium. Thereafter, a copy of said amendment or amendments in the form in which the same were recorded by the officers of the Association shall be delivered to all Unit Owners, but delivery of a copy thereof shall not be a condition precedent to the effectiveness of such amendment or amendments. At any meeting held to consider such amendment or amendments, the written vote of any member of Association shall be recognized if such member is not in attendance at such meeting or represented thereat by proxy, provided such written vote is delivered to the Secretary of the Association at or prior to such meeting.

b. Provided, and anything hereinabove to the contrary notwithstanding, Developer reserves the right to change the design and arrangement of all Units, and to alter the boundaries between Units, so long as Developer owns the Unit or Units so altered. No such change shall increase the number of Units nor alter the boundaries of the Common Property without amendment of this Declaration of Condominium by approval of the Association, Unit Owners and institutional first mortgagees in the manner hereinabove provided. If Developer shall make any changes in Units so authorized, such changes shall be reflected by an amendment to this Declaration. If more than one (1) Unit is concerned, Developer shall apportion between the Units the shares in the Common Property appurtenant to the Units concerned. An amendment to this Declaration reflecting authorized alteration of Unit plans by Developer need be signed and acknowledged only by Developer and need not be approved by the Association, Unit Owners or lienors or mortgagees of Units or of the Condominium, whether or not elsewhere required for amendment. Further provided, anything contained in this Declaration or any exhibits hereto to the contrary notwithstanding, that this Declaration may be amended by the vote of a majority of the Board of Directors of the Association without the vote of the membership, so long as Developer reserves or retains rights as hereinabove provided in paragraph 31, and, in the event of amendment by a majority of the Board of Directors, such amendment shall be transcribed and certified by the President and Secretary of the Association with all of the formalities of a deed in the public records of Indian River County, Florida.

38. Acts of the Association. Unless the approval or action of Unit Owners, or a certain specific percentage of the Board of Directors of the Association, is specifically required in this Declaration, the Articles of Incorporation or By-laws, applicable rules and regulations or applicable law, all approvals or actions required or permitted to be given or taken by the Association shall be given or taken by the Board of Directors, without the consent of the Unit Owners, and the Board may so approve and act through the proper officers of the Association without a specific resolution. When an approval or action of the Association is permitted to be given or taken hereunder or thereunder, such action or approval may be conditioned in any manner the Association deems appropriate, or the Association may refuse to take or give such action or approval without the necessity of establishing the reasonableness of such conditions or refusal.

40. The underlined captions preceding certain paragraphs herein are for convenience only and do not define, limit or construe the contents of such paragraphs and are in no way to be construed as a part of this Declaration.



IN WITNESS WHEREOF, MULLER ENTERPRISES, INC., has caused these presents to be executed in its name by its President and Secretary this 26<sup>th</sup> day of January, 1988 at Vero Beach, Indian River County, Florida.

Signed, sealed and delivered in the presence of:

MULLER ENTERPRISES, INC.

By Henry J. Muller  
President

Attest Cecelia Z. Muller  
Secretary

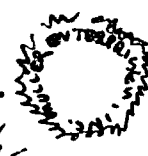

COPY

STATE OF FLORIDA  
COUNTY OF INDIAN RIVER

Before me personally appeared HENRY J. MULLER and CECELIA Z. MULLER, to me well known and known to me to be the individuals described in and who executed the foregoing Declaration of Condominium Establishing River Run C as President and Secretary of the above named MULLER ENTERPRISES, INC., a Florida corporation, and severally acknowledged to and before me that they executed such instrument as such President and Secretary, respectively, of said corporation, and that the seal affixed to the foregoing instrument is the corporate seal of said corporation, and that it was affixed to said instrument by due and regular corporate authority, and that said instrument is the free act and deed of said corporation.

WITNESS my hand and official seal this 26<sup>th</sup> day of January, 1988.

Henry J. Muller  
Notary Public, State of Florida at Large. My Commission expires:

Notary Public State of Florida at Large  
My Commission Expires July 25, 1990  
Bonded By Iowa National Ins. Co.

COPY



COPY

RIVER RUN OF SEBASTIAN CONDOMINIUM ASSOCIATION, INC.  
 SCHEDULE OF COMMON EXPENSES FOR FISCAL 1988  
 COLLECTIBLE BY ASSESSMENT FROM UNIT OWNERS  
 OF RIVER RUN DOCK, A CONDOMINIUM, SEBASTIAN, FLORIDA  
 a 44-Unit Condominium

<u>OPERATING EXPENSES</u>	<u>UNIT</u>	<u>MONTHLY</u>	<u>QUARTERLY</u>	<u>YEARLY</u>
<b>Aministrative</b>				
Managerial Services	\$ 5.00	\$ 220	\$ 660	\$2,640
Office Supplies	.25	11	33	132
Legal & Bank Expenses	.25	11	33	132
Audit Expenses	2.00	88	264	1,056
Association Fee *	.08	3.67	11	44
<b>Operating</b>				
Electricity	5.00	220	660	2,640
Water	5.00	220	660	2,640
Sewer Service	N/A	N/A	N/A	N/A
Trash Removal	N/A	N/A	N/A	N/A
<b>Maintenance</b>				
Pest Control	N/A	N/A	N/A	N/A
Repairs	5.00	220	660	2,640
Grounds	N/A	N/A	N/A	N/A
<b>Insurance</b>	2.08	91.67	275	1,100
<b>Security</b>	N/A	N/A	N/A	N/A
<b>Total</b>	<u>24.66</u>	<u>1,085.34</u>	<u>3,255</u>	<u>13,024</u>
<b>Reserve for replacement **</b>	10.00	440	1,320	5,280
<b>Reserve for deferred Maintenance</b>	N/A	N/A	N/A	N/A
<b>Total Reserves</b>	<u>10.00</u>	<u>440</u>	<u>1,320</u>	<u>5,280</u>
<b>Total expense with reserve</b>	<u>34.66</u>	<u>1,525.34</u>	<u>4,576</u>	<u>18,304</u>
<hr/>				
<b>Assessments:</b>		<u>Monthly</u>	<u>Quarterly</u>	<u>Yearly</u>
With reserves		\$ 34.66	\$ 103.98	\$415.92
Without reserves		\$ 24.66	\$ 73.98	\$295.92

\* Association Fee payable to Department of Business Regulation, Division of Land Sales and Condominiums (Annual fee of \$1.00 for each residential unit operated by the Association due on January 1 of the year following recordation of the Declaration of Condominium.)

\*\* Dock replacement based on 50 year life and estimated replacement cost of \$158,400.

o The developer guarantees the expenses as provided in the Declaration of Condominium Section 18 (a).

oo The developer, as sales owner, intends to waive reserve requirements for fiscal year 1988.

LEGAL DESCRIPTION FOR RIVER RUN DOCKS

A parcel of land lying in Government Lot 4, Section 8, Township 31 South, Range 39 East, Indian River County, Florida, more particularly described as follows:

Commencing at the Southwest corner of the aforementioned Government Lot 4 run S 89°38'22" E a distance of 84.96 feet to the East Right of Way of State Road No. 5 (U.S. Hwy. #1) (120 feet wide); thence N 25°57'59" W along said Easterly Right of Way line a distance of 626.34 feet; thence N 88°20'31" E a distance of 1184.54 feet to the Point of Beginning; thence continue N 88°20'31" E a distance of 51.68 feet; thence S 32°14'32" E a distance of 140.41 feet to a Point on the Safe Upland Line; thence along the Safe Upland Line S 88°32'34" E a distance of 74.50 feet; thence S 14°05'02" W a distance of 46.11 feet; S 21°38'03" W a distance of 23.81 feet; thence S 06°49'45" E a distance of 41.45 feet; thence S 09°41'33" E a distance of 29.51 feet; thence S 29°22'20" E a distance of 26.96 feet; thence S 40°15'23" E a distance of 12.76 feet; thence leaving said Safe Upland Line S 51°43'58" W a distance of 136.50 feet; thence S 01°33'40" E a distance of 154.85 feet; thence N 89°38'22" W a distance of 163.12 feet; thence N 14°41'04" W a distance of 171.67 feet; thence N 44°20'45" E a distance of 128.42 feet; thence N 69°18'01" E a distance of 113.30 feet; thence N 26°50'50" W a distance of 199.46 feet; thence N 09°18'10" W a distance of 53.44 feet to the Point of Beginning.

COPY

COPY

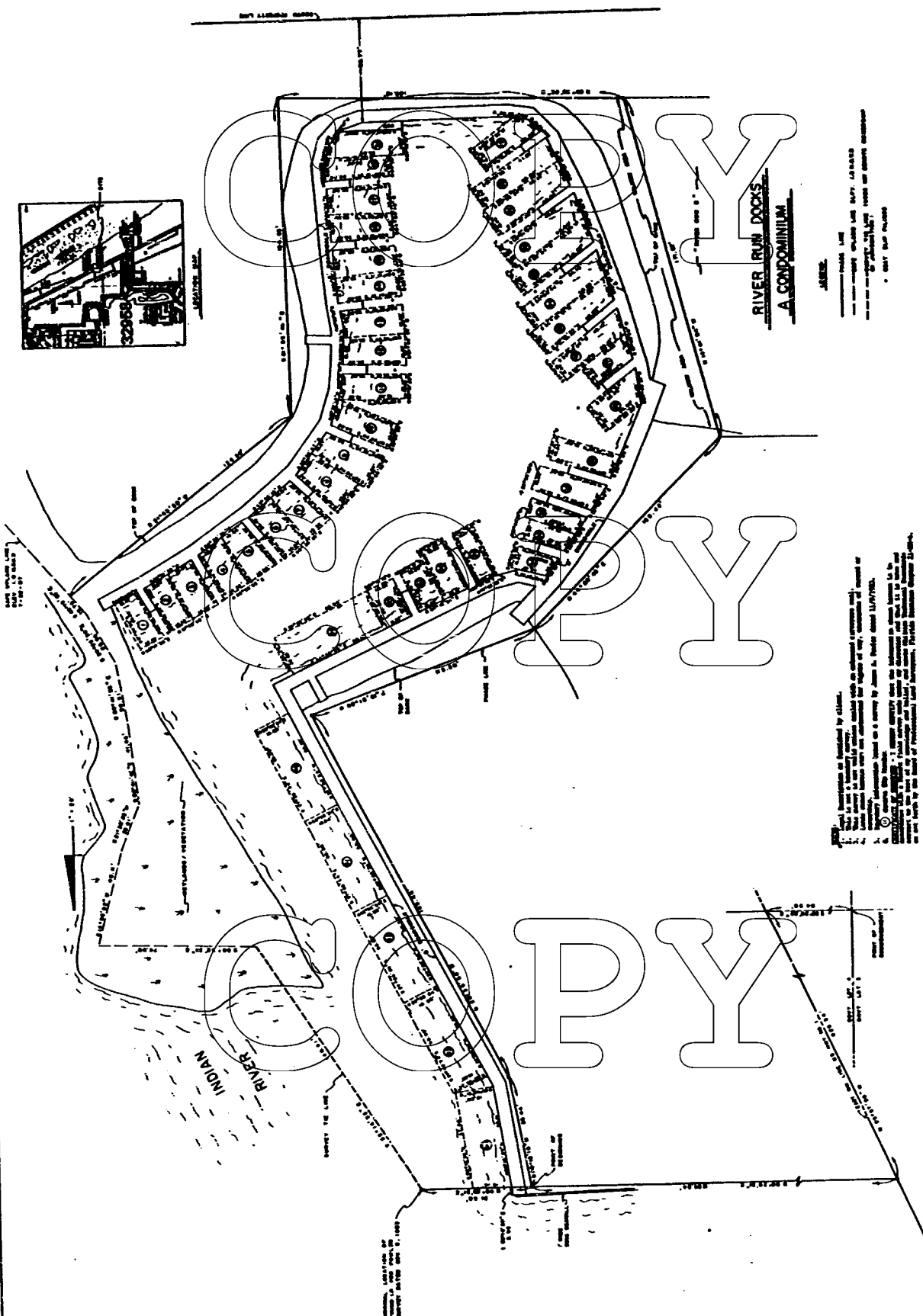
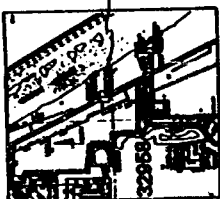

**RIVER RUN DOCKS  
- A CONDOMINIUM**

- LEGEND:**
- FENCE LINE
  - PROPERTY BOUNDARY WITH ADJACENT
  - EXISTING UTILITY TRENCHES AND EXISTING CONDUITS
  - EXISTING POLES

This information is furnished by client. It is not to be used for any other purpose without the express written consent of the architect. The architect assumes no responsibility for the accuracy of the information furnished by the client. The architect's responsibility is limited to the design of the building and the preparation of the contract documents. The architect does not warrant the accuracy of the information furnished by the client. The architect's liability is limited to the amount of the fee paid to the architect. The architect's liability does not extend to any other party. The architect's liability is limited to the amount of the fee paid to the architect. The architect's liability does not extend to any other party.

**MORGAN & EKLAND**  
REGISTERED PROFESSIONAL ARCHITECTS  
1111 W. 10TH AVENUE  
DENVER, COLORADO 80202

**MORGAN & EKLAND**  
REGISTERED PROFESSIONAL ARCHITECTS  
1111 W. 10TH AVENUE  
DENVER, COLORADO 80202

EXHIBIT B

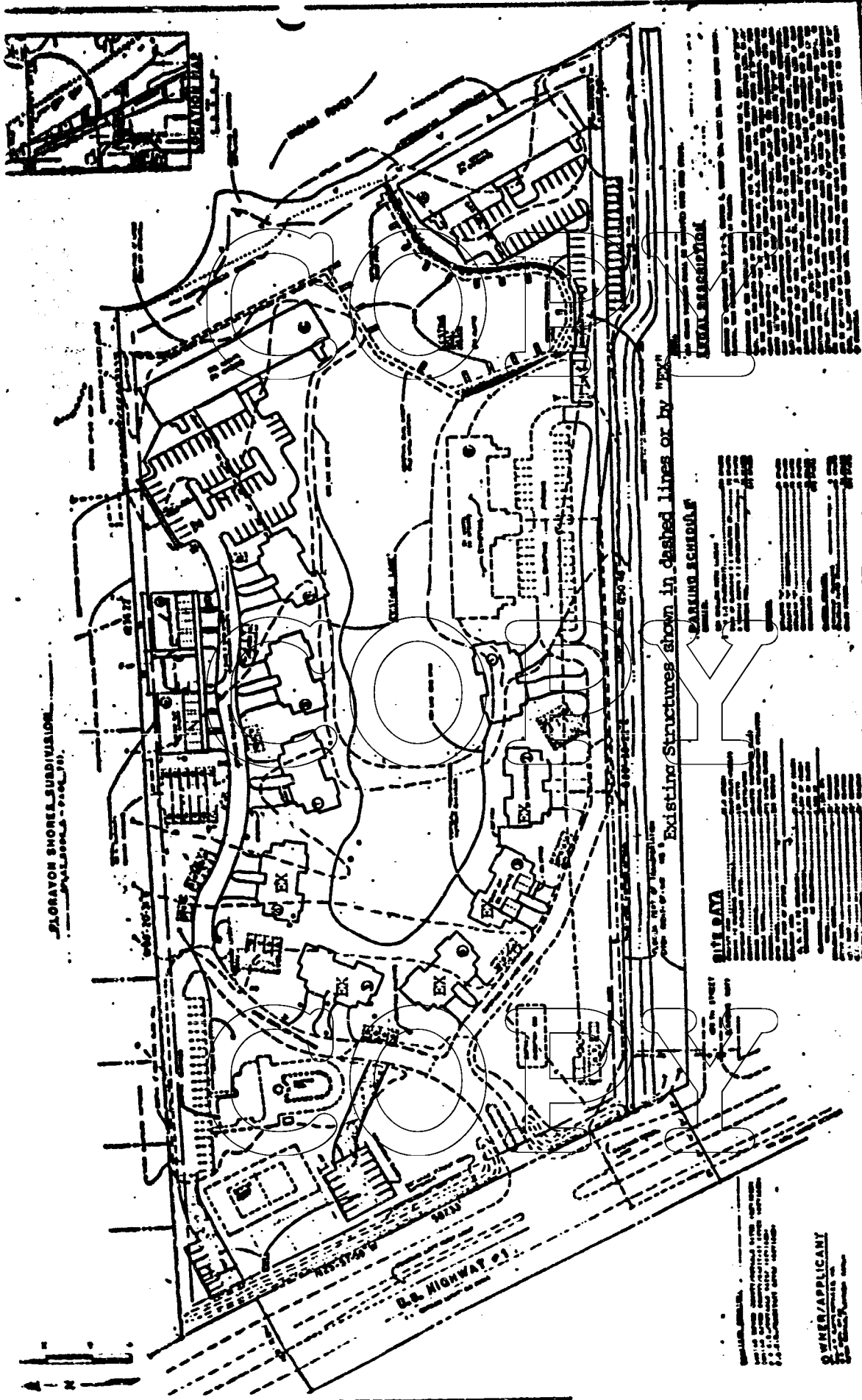

FLORATON SHORES SUBDIVISION  
 PLANNED BY [unreadable]

Existing Structures shown in dashed lines or by "EX"

PARKING SPACES

LEGAL RESERVATION

SITE DATA

Area	Acres
Total Site	1.00
Buildings	0.10
Parking	0.05
Open Space	0.85

PARKING SPACES

Area	Acres
Total Site	1.00
Buildings	0.10
Parking	0.05
Open Space	0.85

LEGAL RESERVATION

UPON SITE PLAN MODIFICATION

RIVER RUN  
 S.E. QUARTER 1

Masteller & Moler Associates, Inc.  
 CONSULTING ENGINEERS - LAND PLANNERS

OWNER/APPLICANT  
 [unreadable]

EXHIBIT C

TYPICAL DOCK DETAIL

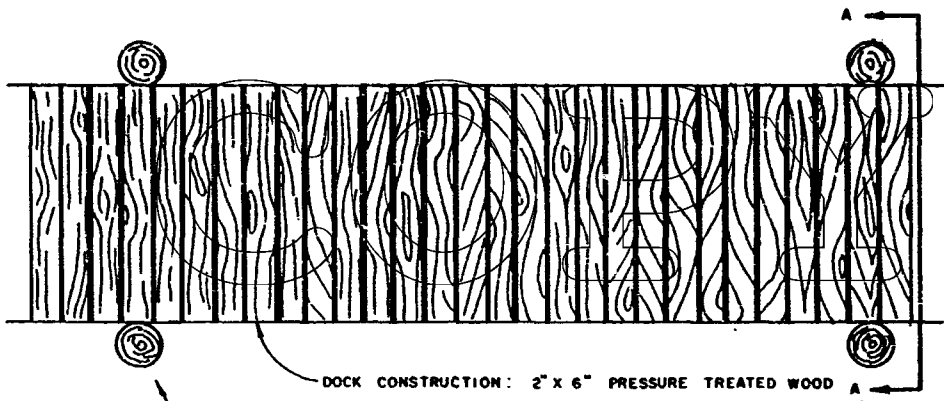

DOCK CONSTRUCTION: 2" x 6" PRESSURE TREATED WOOD

8" DIA. PRESSURE TREATED PILING

COPY

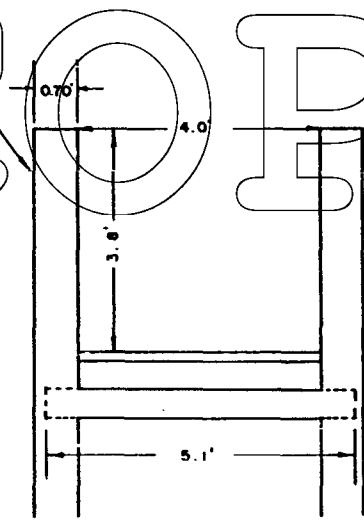

COPY

SECTION "A-A"

SCALE: 1" = 2'

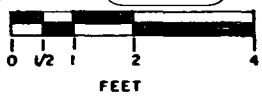

**MORGAN & EKLUND**  
PROFESSIONAL SURVEY CONSULTANTS

2050 40th AVENUE, SUITE 9 1400 SE 4th CT. (B-100)  
VERO BEACH, FL 32980 DEERFIELD BEACH, FL 33441  
305-563-2818 305-421-8882

PRIMARY • MORTGAGE • ROUTE • CONSTRUCTION • TOPOGRAPHIC • CONTROL • HYDROGRAPHIC SURVEYS



RIVER RUN DOCK

A CONDOMINIUM

10920 U.S. Highway 1  
Sebastian, Florida

1. John R. Morgan II, Morgan & Sklund, Inc  
2050 46th Ave  
Vero Bch Fl

**COPY**

, certify as follows:

1. That I am a land surveyor, duly authorized to practice in the State of Florida, having Certificate of Registration No. 3520, State of Florida.
2. That this certificate is made as to RIVER RUN DOCK, a Condominium, located at 10920 U.S. Highway 1, Sebastian, Indian River County, Florida, and in compliance with Chapter 718, Florida Statutes.

3. That all planned improvements, including but not limited to landscaping, utility services and access to each unit, and common element facilities serving RIVER RUN DOCK, a Condominium, as set forth in the foregoing Declaration have been substantially completed so that with the survey of the land as set forth in Exhibit C attached hereto, together with the plot plans as set forth in Exhibit B attached hereto, showing the unit and common elements, together with the wording of the foregoing Declaration, there can be determined therefrom the identification, location and dimensions of each unit, and the common elements of said condominium, and that the aforementioned material is an accurate representation of the location and dimensions of such improvements.

[Signature]  
Land Surveyor, Certificate of  
Registration No. 3520  
State of Florida

Sworn to and subscribed before me this  
31st day of December, 1987.

Debra J. Millerwater  
Notary Public, State of Florida at  
Large. My Commission expires:



**COPY**

EXHIBIT E  
to the Declaration of Condominium

**EASEMENT DEED**

THIS INDENTURE is made this 31<sup>st</sup> day of December, 1987, by MULLER ENTERPRISES, INC., a Florida corporation, hereinafter called the "Developer".

WHEREAS, the Developer is the owner of land described in Attached Exhibit "ED-1" (the "Land");

WHEREAS, the Developer intends, by recording a Declaration of Condominium therefor in the Public Records of Indian River County, Florida, to submit such portion of the Land as is described in Exhibit ED-2 attached hereto (the "Second Parcel") to the condominium form of ownership as a dock condominium, as a part of a series of condominiums ultimately to occupy all of the Land;

WHEREAS, the Developer desires that the owners of boat slips in River Run Dock Condominium will have means of ingress and egress to the Intracoastal Waterway, access to electric utilities and that other owners of condominium units on the Land will be able to use the Walkway area of the Dock Condominium,

NOW THEREFORE, the Developer for good and valuable consideration does hereby grant assign and convey as follows:

1. To RIVER RUN DOCK CONDOMINIUM ASSOCIATION, INC., a Florida non-for-profit corporation, to its members, to the owners of all boat slips for which said Association will have operating responsibilities, their heirs, successors and assigns, a permanent non-exclusive easement for ingress and egress to the Intracoastal Waterway from the Land described in Exhibit ED-2 comprising River Run Dock Condominium over, across and upon the lands described in that certain Grant of Easement recorded in Official Record Book 729, Page 420, of the Public Records of Indian River County, Florida, which easement is shown herein as Exhibit ED-3.

2. To RIVER RUN OF SEBASTIAN CONDOMINIUM ASSOCIATION, INC., a Florida not-for-profit corporation, to its members, to the owners of all condominium units for which said Association will have operating responsibilities, and to all others who may become owners of any portion of the Land, their heirs, successors and assigns, a permanent easement for ingress, egress and regress by foot, in, to upon and over the "Walkway Area" of River Run Dock Condominium, a Condominium, as shown on Exhibit "B" of the Declaration of Condominium, to which this Easement Deed forms Exhibit "F", for all purposes for which a walkway is commonly used.

3. To RIVER RUN DOCK CONDOMINIUM ASSOCIATION, INC., a Florida not-for-profit corporation, to its members, to its members, to the owners of all boat slips for which said Association will have operating responsibilities, their heirs, successors and assigns, a permanent easement over and across that portion of River Run B, a Condominium, as set forth in the Declaration of Condominium recorded in Official Record Book 711, Page 1074, Public Records of Indian River County, Florida, which is described in Exhibit ED-4 hereto, as an electric utility easement.

IN WITNESS WHEREOF, the Developer has caused these presents to be signed in its name the day and year first above written.

Signed, sealed and delivered in the presence of:

MULLER ENTERPRISES, INC.  
a Florida corporation

*Delia J. Muller*

By: *Henry J. Muller*  
Henry J. Muller, President

Attest: *Cecelia Z. Muller*  
Cecelia Z. Muller  
Secretary



EXHIBIT "F" TO DECLARATION



STATE OF FLORIDA  
COUNTY OF INDIAN RIVER

I HEREBY CERTIFY that on this day, before me, an officer duly authorized in the State and County aforesaid to take acknowledgments, personally appeared Henry J. Muller and Cecelia Z. Muller, well known to me to be the President and Secretary respectively of Muller Enterprises, Inc., and they acknowledged executing the foregoing instrument freely and voluntarily under authority duly vested in them by said corporation and that the seal affixed thereto is the true corporate seal of said corporation.

WITNESS my hand and official seal in the State and County last aforesaid this 31<sup>st</sup> day of December, 1987.

COPY

*Henry J. Muller*

Notary Public  
My Commission Expires:

(Notary Seal)

Notary Public State of Florida at Large  
My Commission Expires July 25, 1989  
Bonded By Iowa National Ins. Co.

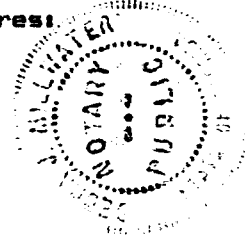

COPY

COPY

EXHIBIT ED-1

Portions of Government Lots 3 and 4, Section 8, Township 31 South, Range 39 East, Indian River County, Florida, more particularly described as follows:

Commencing at the Southwest corner of aforementioned Government Lot 4, run South  $89^{\circ}38'22''$  East, along the South line of said Government Lot 4, also being the South Section line, 84.96 feet to the East right-of-way of State Road No. 5 (U.S. Highway No. 1); thence North  $25^{\circ}57'59''$  West along said right-of-way, 39.01 feet to the Point of Beginning. From the Point of Beginning, continue North  $25^{\circ}57'59''$  West, along said East right-of-way 154.21 feet to its intersection with the East line of aforementioned Government Lot 3; thence continue North  $25^{\circ}57'59''$  West along said right-of-way in Government Lot 3, 394.11 feet to the South line of Floravon Shores Subdivision, as recorded in Plat Book 4, page 78; Public Records of Indian River County, Florida; thence leaving State Road No. 5 right-of-way, run North  $88^{\circ}20'31''$  East along the South line of said Floravon Shores, 173.38 feet to its intersection with the East line of Government Lot 3; thence continue North  $88^{\circ}20'31''$  East, in Government Lot 4, 1,070 feet, more or less, to the Westerly shore of the Indian River; thence meander Southeasterly along the shore of the Indian River 720 feet, more or less, to its intersection with a line which bears South  $49^{\circ}38'22''$  East from the Point of Beginning and is 35 feet North of and parallel with the South line of Government Lot 4; thence North  $89^{\circ}38'22''$  West, 1,300 feet along said line, parallel with the South line of Government Lot 4 to the Point of Beginning.

ALSO BEING DESCRIBED AS:

That part of Government Lot 3, lying East of U.S. Highway No. 1, as now located, and all of Government Lot 4, Section 8, Township 31 South, Range 39 East, Indian River County, Florida, less and except parcels described in Deed Book 85, page 63 and Deed Book 102, page 406, Public Records of Indian River County, Florida and also, less the South 35 feet of said Government Lot 4.

BOTH OF THE FOREGOING TWO (2) DESCRIPTIONS BEING LESS THE FOLLOWING TWO (2) DESCRIBED PARCELS:

Parcel 1: Commencing at the Southwest corner of the aforementioned Government Lot 4, run South  $89^{\circ}38'22''$  East along the South line of said Government Lot 4, also being the South Section line, 84.96 feet to the East right-of-way of State Road No. 5 (U.S. Highway No. 1); thence North  $25^{\circ}57'59''$  West along said right-of-way, 126.01 feet; thence North  $64^{\circ}02'01''$  East, 25.0 feet to the Point of Beginning. From the Point of Beginning, run North  $41^{\circ}54'47''$  East, 114.84 feet; thence South  $52^{\circ}46'11''$  East, 200.0 feet; thence South  $0^{\circ}21'38''$  West, 40.0 feet; thence North  $89^{\circ}38'22''$  West, 199.53 feet; thence North  $25^{\circ}57'59''$  West, 82.63 feet to the Point of Beginning.

AND ALSO EXCEPTING:

Parcel 2: Commencing at the Southwest corner of the aforementioned Government Lot 4, run South  $89^{\circ}38'22''$  East along the South line of said Government Lot 4, also being the South Section line, 84.96 feet to the East right-of-way of State Road No. 5 (U.S. Highway No. 1); thence North  $25^{\circ}57'59''$  West, along said right-of-way, 226.01 feet; thence North  $64^{\circ}02'01''$  East 25.0 feet to the Point of Beginning. From the Point of Beginning, run North  $25^{\circ}57'59''$  West, 165.0 feet; thence North  $64^{\circ}02'01''$  East, 125.0 feet; thence South  $25^{\circ}57'59''$  East, 145.0 feet; thence South  $25^{\circ}22'20''$  West, 32.02 feet; thence South  $64^{\circ}02'01''$  West, 100.0 feet to the Point of Beginning.

EXHIBIT ED-1

LEGAL DESCRIPTION FOR RIVER RUN DOCKS

A parcel of land lying in Government Lot 4, Section 8, Township 31 South, Range 39 East, Indian River County, Florida, more particularly described as follows:

Commencing at the Southwest corner of the aforementioned Government Lot 4 run S 89°38'22" E a distance of 84.96 feet to the East Right of Way of State Road No. 5 (U.S. Hwy. #1) (120 feet wide); thence N 25°57'59" W along said Easterly Right of Way line a distance of 626.34 feet; thence N 88°20'31" E a distance of 1184.54 feet to the Point of Beginning; thence continue N 88°20'31" E a distance of 51.68 feet; thence S 32°14'32" E a distance of 140.41 feet to a Point on the Safe Upland Line; thence along the Safe Upland Line S 88°32'34" E a distance of 74.50 feet; thence S 14°05'02" W a distance of 46.11 feet; S 21°38'03" W a distance of 23.81 feet; thence S 06°49'45" E a distance of 41.46 feet; thence S 09°41'33" E a distance of 29.51 feet; thence S 29°22'20" E a distance of 26.96 feet; thence S 40°15'23" E a distance of 12.76 feet; thence leaving said Safe Upland Line S 51°43'58" W a distance of 136.50 feet; thence S 01°33'40" E a distance of 154.85 feet; thence N 89°38'22" W a distance of 163.12 feet; thence N 14°41'04" W a distance of 171.67 feet; thence N 44°20'45" E a distance of 128.42 feet; thence N 69°18'01" E a distance of 113.30 feet; thence N 26°50'50" W a distance of 199.46 feet; thence N 09°18'10" W a distance of 53.44 feet to the Point of Beginning.

COPY

COPY

EXHIBIT ED-2

445513

JOINT GRANT OF EASEMENT AGREEMENT

THIS JOINT GRANT OF EASEMENT AGREEMENT ("Agreement") is made this 21st day of February, 1986 by and between DEBRA SPANGLER CRIPPEN, f k a DEBRA CRIPPEN SPANGLER, hereinafter referred to as "Crippen" and MULLER ENTERPRISES, INC., hereinafter referred to as "Muller".

WHEREAS, simultaneously with the execution of this Joint Grant of Easement Agreement, Crippen has conveyed to Muller, in fee simple, the real property described in Exhibit "A"; and

WHEREAS, Crippen is the owner in fee simple of the real property described in Exhibit "B"; and

WHEREAS, the real property described in Exhibits "A" and "B" is generally depicted on the sketch attached hereto as Exhibit "C"; and

WHEREAS, the parties have agreed to certain rights and obligations with regard to the boat basin and channel depicted in Exhibit "C".

NOW THEREFORE, in consideration of the premises and the mutual covenants hereinafter set forth, the parties agree as follows:

1. Muller agrees, at its cost and expense, to dredge Crippen's existing boat basin to a depth which is permitted by the controlling governmental authority. Applications for dredging will be made by Crippen. Dredging will be completed within six (6) months following the date permits are issued by the controlling governmental authorities to allow the dredging. Thereafter, dredging of the boat basin shall be the responsibility of Crippen. If no permits are issued for dredging within five (5) years, this covenant shall cease.

2. Muller agrees to be obligated to continue to maintain the channel from the boat basin as depicted on Exhibit "C" from the western boundary of Exhibit "A" property to the Intra Coastal Waterway, to a depth of not less than three (3) feet for purposes of water ingress and egress, from the boat basin owned by Crippen and the boat basin to be constructed by Muller immediately to the south of the real property described in Exhibit "A". This obligation may be subject to governmental regulations and it shall not be a breach thereof if the regulatory authorities in any way limit or prohibit Muller's obligation to maintain as set forth herein.

3. By execution hereof, Muller has granted to Crippen a perpetual non-exclusive easement for ingress and egress over such portion of the channel as exists in Exhibit "A" so that Crippen, her successors and assigns, will have the continuous right of ingress and egress to the Intra Coastal Waterway from the boat basin on the Exhibit "B" property.

4. By execution hereof, Crippen has granted to Muller a perpetual non-exclusive easement for ingress and egress over such portion of the channel which is part of the real property described in Exhibit "B" and which lies east of the real property described in Exhibit "A", so that Muller, its successors and assigns, will have a continuous right of ingress and egress to the Intra Coastal Waterway from Muller's real property that abuts the South boundary of Exhibit "A" property.

5. Exhibit "A" property is not Crippen's homestead.

*Return Coll to: Donna Vero*

0725110420

IN WITNESS WHEREOF, the parties hereto have affixed their hand and seal on the day and year first above written.

Signed, sealed and delivered in the presence of:

*[Handwritten signatures]*  
Virginia Calhoun  
Henry Muller

*[Handwritten signature]*  
DEBRA SEMELER CRIPPEN  
**DPY**  
MULLER ENTERPRISES, INC.  
*[Handwritten signature]*  
BY Henry Muller

STATE OF FLORIDA  
COUNTY OF INDIAN RIVER

I HEREBY CERTIFY that on this day before me, an officer duly authorized to take acknowledgments, personally appeared DEBRA SEMELER CRIPPEN to me known to be the person described in and who executed the foregoing instrument and acknowledged before me that she executed the same.

WITNESS my hand and official seal in the County and State last aforesaid this 25<sup>th</sup> day of February, 1986.



**COPI**  
NOTARY PUBLIC  
My commission expires:  Notary Public, State of Florida  
My Commission Expires July 16, 1987  
STATE OF FLORIDA  
COUNTY OF INDIAN RIVER

I HEREBY CERTIFY that on this day before me, an officer duly authorized to take acknowledgments, personally appeared Henry Muller, President of Muller Enterprises, Inc. to me known to be the person described in and who executed the foregoing instrument and acknowledged before me that he executed the same.

WITNESS my hand and official seal in the County and State last aforesaid this 25<sup>th</sup> day of February, 1986.

*[Handwritten signature]*  
NOTARY PUBLIC

My commission expires:  
**COPI**  
NOTARY PUBLIC STATE OF FLORIDA AT LARGO  
MY COMMISSION EXPIRES DECEMBER 7, 1986

NOT. ST. ... \$ .50  
Florida ... of Civil Code  
Indian River County - by Donna Davis

**DPY**  
1986 FEB 25 PM 4:54  
*[Handwritten signature]*

01257AL0421

COPY

**LEGAL DESCRIPTION:**

**BUYER: MULLER ENTERPRISES, INC.**  
**SELLER: DEBRA CRIPPEN SEMBLER a/k/a DEBRA CRIPPEN**

A portion of Government Lot 4, Section 8, Township 31 South, Range 39 East more particularly described as follows:  
Commencing at the Southwesterly corner of Floravon Shores Subdivision (said point also being on the East right of way of U.S. Highway No. 1), as recorded in Plat Book 4, Page 78, Public Records of Indian River County, Florida, run North  $88^{\circ}20'31''$  East along the South line of said subdivision, 1192.38 feet to the Point of Beginning. From the Point of Beginning run North 4.27 feet; thence North  $50^{\circ}14'36''$  West, 60.52 feet; thence North  $69^{\circ}11'52''$  East, 58.27 feet; thence North  $64^{\circ}00'07''$  East, 37.05 feet; thence run South 78.72 feet to aforesaid South line of Subdivision; thence South  $88^{\circ}20'31''$  West, 41.27 feet to the Point of Beginning.

All the above situate in Indian River County, Florida and containing 0.10 acres, more or less.

Exhibit "A"

COPY

com 0/23 rAbc 0422

**EXHIBIT "B"**

**PARCEL 1**

Tract A, as shown on the plat of FLORAVON SHORES, a subdivision recorded in Plat Book 4, Page 78, Public Records of Indian River County, Florida, less those portions of Tract A described in Official Records Book 26, Page 190, and Official Records Book 289, Page 510, the remainder of said Tract A being more particularly described as follows:  
Commence at the 1/4 corner between Sections 8 and 17, Township 21 South, Range 39 East, Indian River County, Florida, thence South 89°37'30" East a distance of 105.0 feet to the existing river shore as shown on the aforesaid FLORAVON SHORES, thence North 32°14' West a distance of 736.16 feet to the Point of Beginning; thence South 89°04'15" West a distance of 328.00 feet to the Southeast corner of Lot 33, FLORAVON SHORES; thence North 22°22'00" West along the East line of the said Lot 33 and the East end of a 70 foot wide right-of-way, a distance of 214.86 feet; thence North 89°04'15" East a distance of 95.00 feet; thence deflecting to the left an angle of 21°03'00" on a line bearing North 68°01'15" East a distance of 223.68 feet to the said line shown as existing River Shore on the plat of FLORAVON SHORES; thence South 32°14'00" East along said line a distance of 328.94 feet to the Point of Beginning. Containing therein an area of 85,821 square feet or 1.97 acres, more or less.

**PARCEL 1A**

Commence at the 1/4 corner between Sections 8 and 17, Township 21 South, Range 39 East, Indian River County, Florida; thence South 89°37'30" East a distance of 105.00 feet to the existing River Shore as shown on the plat of FLORAVON SHORES, a subdivision recorded in Plat Book 4, Page 78, Public Records of Indian River County, Florida; thence North 32°14' West along said existing River Shore line a distance of 736.16 feet to the Southeast corner of Tract A as shown on the aforementioned plat of FLORAVON SHORES and the Point of Beginning; thence North 32°14' West still along the line as shown on the said plat of FLORAVON SHORES to the existing River Shore a distance of 328.94 feet; thence North 89°01'15" East a distance of 70.35 feet; thence South 25°56'34" East a distance of 37.43 feet; thence North 83°43'31" East a distance of 29.20 feet to a point of curve; thence on the arc of a curve to the right, having a radius of 48.00 feet and a central angle of 70°47'40" a distance of 39.31 feet to a point of tangency; thence South 25°28'29" East a distance of 150.20 feet; thence South 14°36'25" East a distance of 74.99 feet; thence South 72°29'02" West a distance of 40 feet more or less to the existing shore line of the Indian River; thence continue in a southerly direction along said shore line to a Point of Intersection with the South property line of FLORAVON SHORES; thence South 89°04'15" West a distance of 20 feet, more or less, to the Point of Beginning. Containing therein an area of 31,238 square feet or 0.717 acres, more or less.

**LESS AND EXCEPT THE FOLLOWING:**

A portion of Government Lot 4, Section 8, Township 21 South, Range 39 East more particularly described as follows:  
Commencing at the Southwesterly corner of Floravon Shores Subdivision; said point also being on the East right of way of U.S. Highway No. 1; as recorded in Plat Book 4, Page 78, Public Records of Indian River County, Florida, run North 80°20'31" East along the South line of said subdivision, 1192.30 feet to the Point of Beginning. From the Point of Beginning run North 4.27 feet; thence North 60°14'30" West, 60.52 feet; thence North 69°11'52" East, 50.27 feet; thence North 64°00'07" East, 37.05 feet; thence run South 78.72 feet to aforesaid South line of Subdivision; thence South 80°20'31" West, 41.27 feet to the Point of Beginning.

All the above situate in Indian River County, Florida and containing 0.10 acre or less.



RIVER

INDIAN

Exhibit "A" property is shaded.  
Exhibit "B" property is Parcel 1 and Parcel 2,  
less the Exhibit "A" property.

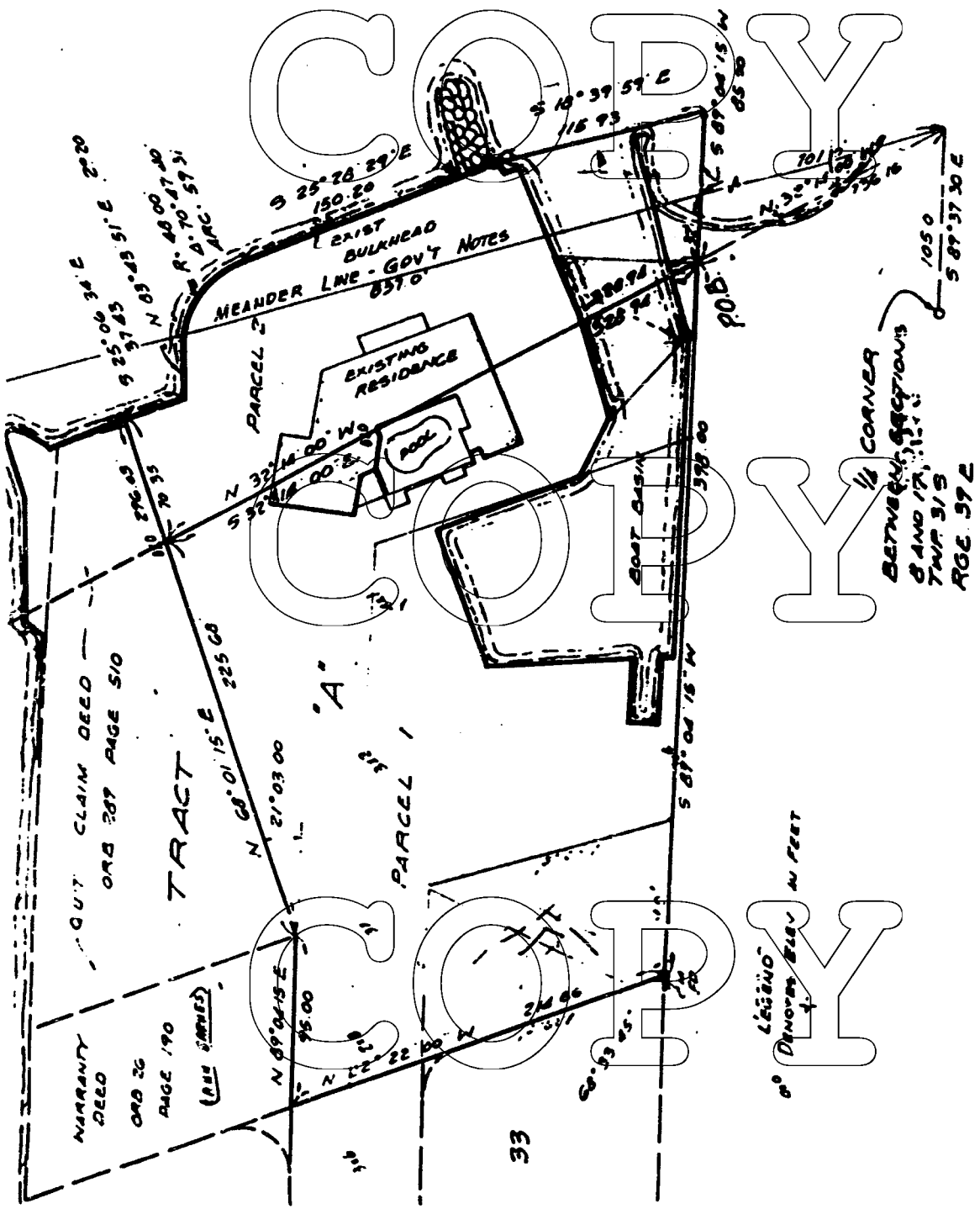

COPY

COPY

COPY

EXHIBIT "C"

2024



LEGAL DESCRIPTION

A portion of Government Lot 4, Section 8, Township 31 South, Range 39 East, Indian River County, Florida, more particularly described as follows: Commencing at the Southwest corner of the aforementioned Government Lot 4, run South  $89^{\circ}38'22''$  East, 84.96 feet to the East right-of-way of State Road No. 5 (U.S. Highway No. 1); thence North  $25^{\circ}57'59''$  West, along said right-of-way, 39.01 feet; thence run South  $89^{\circ}38'22''$  East, on a line parallel with and 35 feet North of aforementioned South line of Government lot 4, 553.0 feet; thence North  $0^{\circ}21'38''$  East, 40.0 feet to the Point of Beginning. From the Point of Beginning, run North  $13^{\circ}17'57''$  East, 166.94 feet; thence North  $89^{\circ}37'10''$  East, 238.08 feet; thence South  $14^{\circ}41'04''$  East, 171.67 feet; thence North  $89^{\circ}38'22''$  West, 320.0 feet to the Point of Beginning.

COPY

COPY

EXHIBIT ED-4

# State of Florida



Department of State

# COPY

I certify that the attached is a true and correct copy of the Articles of Incorporation of RIVER RUN OF SEBASTIAN CONDOMINIUM ASSOCIATION, INC., a corporation organized under the Laws of the State of Florida, filed on February 24, 1984, as shown by the records of this office.

The charter number of this corporation is N01637.

# COPY

Given under my hand and the Great Seal of the State of Florida, at Tallahassee, the Capital, this 27th day of February, 1984.



CFH-101

George Firestone  
Secretary of State

# COPY

Exhibit G

NOV 1

ARTICLES OF INCORPORATION

OF

RIVER RUN OF SEBASTIAN

CONDOMINIUM ASSOCIATION, INC.

FILED

1981 FEB 24 11:06

SECRETARY OF STATE  
TALLAHASSEE, FLORIDA

In order to form a corporation under and in accordance with the provisions of the laws of the State of Florida for the formation of Corporations Not for Profit, the undersigned hereby incorporates a corporation for the purpose and with the powers hereinafter mentioned, and, to that end, does, by these Articles of Incorporation, set forth:

COPY

I

The name of the proposed corporation shall be RIVER RUN OF SEBASTIAN CONDOMINIUM ASSOCIATION, INC., hereinafter referred to as the "Corporation" and the "Association".

II

The purpose for which the Association is organized is to provide an entity pursuant to the Condominium Act, which is Chapter 718, Florida Statutes, 1983, as amended, for the operation of a group of no fewer than one (1) and no more than five (5) condominiums (the "Condominiums") that may be established by MULLER ENTERPRISES, INC., a Florida corporation, hereinafter called the "Developer", upon the lands described in Exhibit AI-A hereto, and to purchase, own, operate, lease, sell, trade and otherwise deal with such property, or other property, whether real or personal, as may be necessary or convenient in the administration of said Condominiums. The Corporation shall be conducted as a non-profit organization for the benefit of its members.

COPY

COPY

VII

The powers of the Association will include and be governed by the following provisions:

1. The Association will have all of the common law and statutory powers of a corporation not for profit that are not in conflict with the terms of these Articles, the Declarations of Condominium of the Condominiums, the Bylaws of this Corporation or the Condominium Act.

O.R. 0764 PG 0378

2. The Association will have all of the powers and duties set forth in the Condominium Act; and it will have all of the powers and duties reasonably necessary to operate said Condominiums pursuant to the several Declarations of Condominium, as they may be amended from time to time, including but not limited to the following:

a. To make and establish reasonable rules and regulations governing the use and maintenance standards of the Condominiums, as said terms may be defined in the several Declarations of Condominium to be recorded.

b. To make and collect assessments against members to defray the costs, expenses and losses of the Condominiums.

c. To use the proceeds of assessments in the exercise of its powers and duties.

d. To maintain, repair, replace and operate the Condominium properties.

e. To purchase insurance for the Condominium properties and insurance for the protection of the Association and its members as Condominium unit owners.

f. To reconstruct improvements after casualty and to further improve the Condominium properties.

g. To make and amend reasonable regulations respecting the use of the Condominium properties.

h. To approve or disapprove the transfer, lease, mortgage and ownership of Condominium units as may be provided by the several Declarations of Condominium and the By-laws of the Association.

i. To enforce by legal means the provisions of the Condominium Act, the several Declarations of Condominium, these Articles, the By-laws of the Association and the regulations for the use of the Condominium properties.

j. To contract for the management and operation of the Condominiums, including their common properties; and to thereby delegate all powers and duties of the Association, except such as are specifically required to have the approval of the Board of Directors or of the membership of the Association.

k. To employ personnel to perform the services required for the proper management and operation of the Condominiums.

1. To own and hold fee simple title to lands, within reasonable proximity to the Condominium properties upon which recreational facilities, entranceways, walkways, parking areas, and like facilities are or may be constructed for the benefit of Condominium unit owners, and to manage, control and maintain the same; provided, however, that such facilities shall and must be for the use and enjoyment of all unit owners in the Condominiums to be established upon the lands described in Article II hereof. The Association shall assess each unit when completely constructed for its pro-rata share of the costs and expenses of the operating and maintaining of said facilities.

m. To lease such portions of the common properties of the Condominiums to third parties in connection with the management and maintenance of the said Condominiums.

n. All such other powers as are necessary or desirable for the effectuation of the above purposes and not otherwise prohibited by law.

3. All funds, except such portions thereof as are expended for the common expenses of the Condominiums and the title to all property, will be held in trust for the members of the Association, in accordance with their respective interests under the several Declarations of Condominium and in accordance with the provisions of these Articles of Incorporation and the By-laws of the Association.

4. The powers of the Association will be subject to and will be exercised in accordance with the provisions of the several Declarations of Condominium and the By-laws of the Association.

#### IV

The qualification of the members, the manner of their admission to membership and termination of such membership and voting by members shall be as follows:

1. The members of the Association will consist of all of the record owners of the Condominium units in the Condominiums

for which the Association has operating responsibility, and no other persons or entities shall be entitled to membership except as provided in Section 4 of this Article IV and as provided in Article VIII; and after termination of any of the Condominiums will consist of those who were members of the terminated Condominium(s) at the time of such termination, their successors and assigns and the members of such of the Condominiums, if any, as are not terminated. Membership shall be established (i) by acquiring and recording evidence in the public records of Indian River County of fee title to a unit in any of the Condominiums, or by acquiring and recording evidence of a fee ownership interest therein, whether by conveyance, devise, judicial decree or otherwise and (ii) by delivery of a copy of said evidence to the Association, and the membership of any person shall be automatically terminated upon his being divested of all title to or his entire fee ownership interest in any unit, except that nothing herein contained shall be construed as terminating the membership of any person who may own two or more units, or who may own a fee ownership interest in two or more units, so long as any such person shall retain title to or a fee ownership interest in any unit.

2. The share of a member in the funds and assets of the Association cannot be assigned, hypothecated or transferred in any manner except as an appurtenance to his Condominium unit. The funds and assets of the Association shall belong solely to the Association subject to the limitation that the same be expended, held or used for the benefit of the membership and for the purposes authorized herein, in the several Declarations of Condominium, and in the By-laws which shall be hereafter adopted.

3. On all matters on which the membership shall be entitled to vote, there shall be only one (1) vote for each Condominium unit in the Condominiums in such manner as may be provided in the By-laws hereafter adopted by the Association. Should any member own more than one Condominium unit, such member shall be entitled to exercise or cast as many votes as he owns units in the manner provided by said By-laws.

4. Until such time as at least one (1) of the properties described in Article II hereof is submitted to a plan of condominium ownership by the recordation of a Declaration of Condominium, the membership of the Association shall be comprised of the subscriber of these Articles of Incorporation, and such subscriber shall be entitled to cast one vote on all matters on which the membership shall be entitled to vote.

**COPY**  
V  
The Corporation shall have perpetual existence.

VI

The principal office of the Corporation shall initially be located at 3339 Cardinal Drive, Vero Beach, Indian River County, Florida, but the Corporation may maintain offices and transact business in such other places within or without the State of Florida as may be designated from time to time by the Board of Directors.

**COPY**  
VII

The affairs of the Corporation shall be managed by the President of the Corporation, assisted by the Vice Presidents, if any, a Secretary and a Treasurer, and Assistant Secretaries and Assistant Treasurers, if any, subject to the directions of the Board of Directors. The Board of Directors or the President, with the approval of the Board of Directors, may employ a managing agent and/or such other managerial and supervisory personnel or entities to administer or assist in the administration of the operation and management of any of the Condominiums and the affairs of the Corporation, and any such person or entity may be a member of the Corporation or a director or officer of the Corporation, or may have directors or officers in common with the Corporation, as the case may be.

VIII

1. The number of directors on the first Board of Directors (the "First Board"), the "Initial Elected Board", as hereinafter defined, and all Boards elected prior to the annual members' meeting following the Developer's Resignation Event, as

hereinafter defined, shall be three (3). The number of directors elected by the "Purchaser Members" (as hereinafter defined) subsequent to the Initial Elected Board, shall be as provided in this Article VIII.

2. The names and addresses of the persons who are to serve as the First Board are as follows:

<u>NAME</u>	<u>ADDRESS</u>
Henry J. Muller	3339 Cardinal Drive Vero Beach, FL 32963
Jack P. Schleifer	60 East 42nd Street New York, NY 10165
Cecelia Z. Muller	3339 Cardinal Drive Vero Beach, FL 32963

Developer reserves the right to designate successor directors to serve on the Board for so long as it has the right to designate any directors, as hereinafter provided.

3. Upon the conveyance by Developer to unit owners other than Developer ("Purchaser Members") of fifteen percent (15%) or more of all units in any one Condominium, the Purchaser Members shall be entitled to elect one director, which election shall take place at a special meeting of the membership to be called by the Board for such purpose (the "Initial Election Meeting"). At the Initial Election Meeting, one (1) of the directors previously designated by the Developer shall submit his or her written resignation, which shall be accepted, and the Purchaser Members present in person or by proxy shall thereupon proceed to elect one (1) director by written ballot, all nominations to be from the floor. The Board as so reconstituted shall be the "Initial Elected Board". The remaining two (2) directors shall retain their positions until they resign or are replaced by the Developer, which right of replacement at any time is reserved by the Developer. Subject to the other provisions of this Article VIII, the Initial Elected Board shall serve until the next Annual Members' Meeting, at which time the Purchaser Members shall elect another Director to replace the single director elected by such Purchaser Members at the Initial Election Meeting; provided, however, that any director elected by the Purchaser Members shall be eligible to succeed himself. Directors previously designated



COPY

written resignation, which shall be accepted, and the Purchaser Members present in person or by proxy shall proceed to elect one (1) additional director by written ballot, all nominations to be from the floor; the other two (2) directors to retain their positions until the next required election, in the case of directors elected by the Purchaser Members, or their resignation or replacement, in the case of directors designated by the Developer. Upon the election of the new director by the Purchaser Members at the Majority Election Meeting, the Board of Directors as so reconstituted shall meet and proceed to elect a new President of the Association from among the directors elected by the Purchaser Members, the incumbent President to submit his resignation as President at such time. No other officers shall be replaced at such time.

7. The directors shall continue to be either elected or designated, as described in this Article VIII, at each subsequent annual members' meeting, until the annual members' meeting following the Developer's Resignation Event.

8. The Initial Election meeting and the Majority Election Meeting shall be called by the Association, through its Board, within sixty (60) days after the Purchaser Members are entitled to elect a director or the majority of directors, as the case may be. A notice of meeting shall be forwarded to all Members in accordance with the By-laws; provided, however, that the Members shall be given at least thirty (30) but not more than forty (40) days' notice of such meeting. The notice shall also specify the number of directors to be elected by the Purchaser Members and the remaining number of directors designated by the Developer.

9. Developer shall cause its remaining designated director(s) to resign when Developer no longer holds at least five percent (5%) of the units in any one of the Condominiums for sale in the ordinary course of business; provided, however, that the Developer may at any time, in its sole discretion, cause the voluntary resignation of all of the directors designated by it. The happening of either such event is hereby referred to as the "Developer's Resignation Event". Upon the Developer's Resignation Event, the directors elected by Purchaser Members shall

by the Developer shall retain their positions through each annual members' meeting until they resign or are replaced by the Developer, which right of replacement at any time is reserved by the Developer. One director shall continue to be so elected at each subsequent annual members' meeting until such time as the Purchaser Members are entitled to elect not less than a majority of the directors on the Board.

4. Purchaser Members are entitled to elect not less than a majority of the Board upon the happening of any of the following events, whichever may first occur:

a. Three (3) years after sales by Developer of fifty percent (50%) of all of the units in the Condominiums have been closed, which closings shall be evidenced by the recording of instruments of conveyance of units to each of such Purchaser Members amongst the Public Records of Indian River County, Florida.

b. Three (3) months after sales by Developer of ninety percent (90%) of all units in the Condominiums have been closed, which closings shall be evidenced by the recording of instruments of conveyance of units to each of such Purchaser Members amongst the Public Records of Indian River County, Florida.

c. When all of the units in the Condominiums have been completed (as evidenced by the issuance of Certificates of Occupancy for all of same) and some have been sold to Purchaser Members and none of the others are being offered for sale by Developer in the ordinary course of business; or

d. When some of the units have been conveyed to Purchaser Members and none of the others are being constructed or offered for sale by Developer in the ordinary course of business.

5. The election of not less than a majority of directors by the Purchaser Members shall occur at a special meeting of the Membership to be called by the Board for such purpose (the "Majority Election Meeting").

6. At the Majority Election Meeting, one of the two directors designated by the Developer shall submit his or her

elect successor directors to fill the vacancy or vacancies caused by the resignation of the remaining designated director(s). These successor directors shall serve until the next annual members' meeting and until their successors are elected and qualified.

10. At each annual members' meeting held subsequent to the year in which the Developer's Resignation Event occurs, all of the directors shall be elected by the members and, upon the affirmative vote of a majority of the members, the Board may be expanded to not more than nine (9) directors.

11. The resignation of a director who has been elected or designated by the Developer or the resignation of an officer of the Association who has been elected by the First Board or the Initial Elected Board shall, to the extent permissible by law, remise, release, acquit, satisfy and forever discharge such officer or director of and from any and all manner of action and actions, cause and causes of action, suits, debts, dues, sums of money, accounts, reckonings, bonds, bills, specialties, covenants, contracts, controversies, agreements, promises, variances, trespasses, damages, judgments, executions, claims and demands whatsoever, in law or in equity, which the Association or Purchaser Members had, now have, or which any personal representative, successor, heir or assign or the Association or Purchaser Members hereafter can, shall or may have against said officer or director for, upon, or by reason of any matter, cause or thing whatsoever through the day of such resignation.

12. Within sixty (60) days of the date of the Majority Election Meeting, on such date as it shall in its sole discretion determine (the "Turnover Date"), the Developer shall relinquish control of the Association to the Purchaser Members as required by §718.301, Florida Statutes, by submitting to the President of the Association, who shall accept them on behalf of the Association, the following: (1) resignations of all officers of the Association previously elected or appointed by a Developer-controlled Board of Directors, if any such remain in office; (2) all personal property of the Association or of the unit owners held or controlled by the Developer or its agent; and (3) such

other items as are required to be turned over by §718.301, Florida Statutes; provided, however, that the accounting for all Association funds required to be presented to the Association by the Developer pursuant to the terms of §718.301(5)(c), Fla. Stat., may be remitted to the President of the Association by the independent auditor responsible for such accounting within such time after the Turnover Date as shall be needed by such independent auditor for the making of such accounting but in no event later than ninety (90) days after the Turnover Date and provided, further, that in the event that the said auditor fails to remit the results of the said accounting to the President in a timely manner, neither Developer nor any of Developer's principals, employees or agents shall be liable therefor or for any consequences thereof.

IX

The Board of Directors shall elect a President, Secretary and Treasurer, and as many Vice Presidents, Assistant Secretaries and Assistant Treasurers as the Board of Directors shall determine. The President shall be elected from among the membership of the Board of Directors, but no other officer need be a Director. The same person may hold two offices, the duties of which are not incompatible; provided, however, that the office of President and Vice President shall not be held by the same person, nor shall the office of President and Secretary or Assistant Secretary be held by the same person.

X

The subscriber to these Articles of Incorporation is the person named herein to act and serve as member of the first Board of Directors of the Corporation, the name of which subscriber and his respective post office address is more particularly set forth below.

Henry J. Muller

3339 Cardinal Drive  
Vero Beach, FL 32963

XI

The original By-laws of the Corporation shall be adopted by a majority vote of the first Board of Directors of the Corpo-

ration, and, thereafter, such By-laws may be altered, amended or rescinded only in such manner as the By-laws may provide.

XII

The officers of the Corporation who shall serve until the first election under these Articles of Incorporation shall be the following:

<u>NAME</u>	<u>OFFICE</u>
Henry J. Muller	President
Jack P. Schleifer	Vice President
Cecelia Z. Muller	Secretary-Treasurer

XIII

The Association shall indemnify any person who was or is a party or is threatened to be made a party to any threatened, pending or contemplated action, suit or proceeding, whether civil, criminal, administrative or investigative, by reason of the fact that he is or was a director, employee, officer or agent of the Association, against expenses (including attorneys' fees and appellate attorneys' fees), judgments, fines and amounts paid in settlement as long as actually and reasonably incurred by him in connection with such action, suit or proceeding, if he acted in good faith and in a manner he reasonably believed to be in or not opposed to the best interest of the Association, and, with respect to any criminal action or proceeding, had no reasonable cause to believe his conduct was unlawful, except that no indemnification shall be made in respect of any claim, issue or matter as to which such person shall have been adjudged to be liable for gross negligence or misfeasance or malfeasance in the performance of his duty to the Association, unless and only to the extent that the court in which such action or suit was brought shall determine upon application that despite the adjudication of liability, but in view of all of the circumstances of the case, such person is fairly and reasonably entitled to indemnification for such expense which shall court shall deem proper. The termination of any action, suit or proceeding by judgment, order, settlement, conviction or upon a plea of nolo contendere or its equivalent shall not, of itself, create a presumption that the person did not act in good faith and in a

maner which he reasonably believed to be in or not opposed to the best interest of the Association, and with respect to any criminal action or proceeding, that the person had reasonable cause to believe that his conduct was unlawful.

XIV

An amendment or amendments to these Articles of Incorporation may be proposed by the Board of Directors of the Corporation acting upon a vote of the majority of the directors, or by a majority of the members of the Corporation, whether meeting as members or by instruments in writing signed by them. Upon any amendment or amendments to these Articles of Incorporation being proposed by said Board of Directors or members, such proposed amendment or amendments shall be transmitted to the President of the Corporation or other officer of the Corporation in the absence of the President, who shall thereupon call a special meeting of the members of the Corporation for a date not sooner than twenty (20) days nor later than sixty (60) days from the receipt by him of the proposed amendment or amendments, and it shall be the duty of the Secretary to give to each member written notice or printed notice of such meeting stating the time and place of the meeting and reciting the proposed amendment or amendments in reasonably detailed form, which notice shall be mailed or presented personally to each member not less than fourteen (14) nor more than thirty (30) days before the date set for such meeting. If mailed, such notice shall be deemed to be properly given when deposited in the United States mail, addressed to the member at his post office address as it appears on the records of the Corporation, the postage thereon prepaid. Any member may, by written waiver of notice signed by such member, waive such notice, and such waiver when filed in the records of the Corporation, whether before or after the holding of the meeting, shall be deemed equivalent to the giving of such notice to such member. At such meeting, the amendment or amendments proposed must be approved by an affirmative vote of a majority present at such meeting, in order for such amendment or amendments to become effective unless otherwise expressly

required by Florida law. Thereupon, such amendment or amendments of these Articles of Incorporation shall be transcribed and certified in such form as may be necessary to register the same in the office of the Secretary of State of the State of Florida, and, upon the registration of such amendment or amendments with said Secretary of State, a certified copy thereof shall be recorded in the public records of Indian River County, Florida, within thirty (30) days from the date on which the same are so registered. At any meeting held to consider such amendment or amendments of these Articles of Incorporation, the written vote of any member of the Corporation shall be recognized, if such member is not in attendance at such meeting or represented thereat by proxy, provided such written vote is delivered to the Secretary of the Corporation at or prior to such meeting.

Notwithstanding the foregoing, so long as MULLER ENTERPRISES, INC., shall have the right hereinabove provided to select a majority of the Board of Directors of the Corporation, an amendment or amendments to these Articles of Incorporation may be adopted and approved by an affirmative vote of a majority of the Board of Directors of the Corporation in order for such amendment or amendments to become effective. Thereupon, such amendment or amendments to these Articles of Incorporation shall be transcribed and certified in such form as may be necessary to register the same in the office of the Secretary of State of the State of Florida, and, upon such registration, a certified copy thereof shall be recorded in the public records of Indian River County, Florida. Moreover, so long as MULLER ENTERPRISES, INC. shall have the right to select a majority of the Board of Directors of the Corporation, no amendment to these Articles of Incorporation shall be adopted or become effective without the affirmative vote of a majority of the Board of Directors.

Notwithstanding the foregoing provisions of this Article XIV, no amendment to these Articles of Incorporation which shall abridge, amend or alter the right of MULLER ENTERPRISES, INC. to designate and select members of each Board of Directors of the corporation, as provided in Article VIII hereof, may be adopted

or become effective without the prior written consent of MULLER ENTERPRISES, INC.

FILED  
FEB 24 AM 11:07

SECRETARY OF STATE  
TALLAHASSEE, FLORIDA

XV

The resident agent for the service of process within the

State shall be:

NAME

Henry J. Muller

ADDRESS

3339 Cardinal Drive  
Vero Beach, Florida 32963

IN WITNESS WHEREOF, we have hereunto set our hands and seals this 7 day of February, 1984, at Vero Beach, Florida.

  
Henry J. Muller (SEAL)

STATE OF FLORIDA  
COUNTY OF INDIAN RIVER

Before me, the undersigned authority, personally appeared HENRY J. MULLER, who, being by me first duly sworn, acknowledged that he executed the foregoing Articles of Incorporation for the purposes therein expressed this 7 day of February, 1984.

  
Notary Public, State of Florida at Large. My Commission Expires:

Notary Public, State of Florida at Large  
My Commission Expires July 23, 1984

COPY



FILED

CERTIFICATE DESIGNATING PLACE OF BUSINESS OR HOME OFFICE, FOR THE SERVICE OF PROCESS WITHIN THIS STATE, NAMING AGENT UPON WHOM SERVICE OF PROCESS MAY BE MADE.

SECRETARY OF STATE  
TALLAHASSEE, FLORIDA

In pursuance of Chapter 48.091, Florida Statutes, the following is submitted in compliance with the said Act:

First, that RIVER RUN OF SEBASTIAN CONDOMINIUM ASSOCIATION, INC., desiring to organize under the laws of the State of Florida with its principal office, as indicated in the articles of incorporation, at the City of VERO BEACH, County of INDIAN RIVER, State of FLORIDA, has named HENRY J. MULLER, located at 3339 Cardinal Drive, Vero Beach, Indian River County, Florida 32963, as its agent to accept service of process within this state.

ACKNOWLEDGMENT

Having been named to accept service of process for the above-stated corporation, at the place designated in this certificate, I hereby accept to act in this capacity, and agree to comply with the provisions of the said Act relative to keeping open said office.

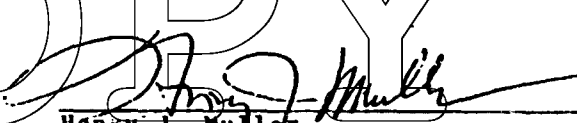
  
Henry J. Muller  
Resident Agent

COPY

1934 FEB 24 AM 11:07

Portions of Government Lots 3 and 4, Section 8, Township 31 South, Range 39 East, Indian River County, Florida, more particularly described as follows:

Commencing at the Southwest corner of aforementioned Government Lot 4, run South  $89^{\circ}38'22''$  East, along the South line of said Government Lot 4, also being the South Section line, 84.96 feet to the East right-of-way of State Road No. 5 (U.S. Highway No. 1); thence North  $25^{\circ}57'59''$  West along said right-of-way, 39.01 feet to the Point of Beginning. From the Point of Beginning, continue North  $25^{\circ}57'59''$  West along said East right-of-way, 154.21 feet to its intersection with the East line of aforementioned Government Lot 3; thence continue North  $25^{\circ}57'59''$  West along said right-of-way in Government Lot 3, 394.11 feet to the South line of Floravon Shores Subdivision, as recorded in Plat Book 4, page 78, Public Records of Indian River County, Florida; thence leaving State Road No. 5 right-of-way, run North  $88^{\circ}20'31''$  East along the South line of said Floravon Shores, 173.38 feet to its intersection with the East line of Government Lot 3; thence continue North  $88^{\circ}20'31''$  East, in Government Lot 4, 1,070 feet more or less, to the Westerly shore of the Indian River; thence meander Southeasterly along the shore of the Indian River 720 feet, more or less, to its intersection with a line which bears South  $89^{\circ}38'22''$  East from the Point of Beginning and is 35 feet North of and parallel with the South line of Government Lot 4; thence North  $89^{\circ}38'22''$  West, 1,300 feet along said line, parallel with the South line of Government Lot 4 to the Point of Beginning.

## ALSO BEING DESCRIBED AS:

That part of Government Lot 3, lying East of U.S. Highway No. 1, as now located, and all of Government Lot 4, Section 8, Township 31 South, Range 39 East, Indian River County, Florida, LESS AND EXCEPT parcels described in Deed Book 85, page 63, and Deed Book 102, page 406, Public Records of Indian River County, Florida and also LESS the South 35 feet of said Government Lot 4.

COPY

# State of Florida



Department of State

# COPY

I certify that the attached is a true and correct copy of Certificate of Amendment to Articles of Incorporation for RIVER RUN OF SEBASTIAN CONDOMINIUM ASSOCIATION, INC., a Florida corporation, filed on March 29, 1984, as shown by the records of this office.

The charter number of this corporation is N01637.

# COPY

Given under my hand and the Great Seal of the State of Florida, at Tallahassee, the Capital, this the 29th day of March, 1984.

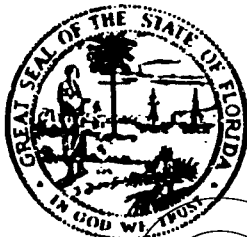

CER 101

George Firestone  
Secretary of State

# COPY

ARTICLES OF AMENDMENT TO THE  
ARTICLES OF INCORPORATION OF

River Run of Sebastian  
Condominium Association, Inc.

To: Department of State  
Tallahassee, Florida 32301

Pursuant to the provisions of Sections 607.187 and 617.017 of the Florida Statutes, the undersigned corporation adopts the following articles of amendment to its articles of incorporation:

1. The name of the corporation is RIVER RUN OF SEBASTIAN CONDOMINIUM ASSOCIATION, INC.
2. The corporation is a not-for-profit corporation organized under Florida law in 1984.
3. The articles of incorporation of the corporation do not contain express provisions governing the manner in which amendments to the said articles are to be adopted.
4. The corporation has no members at the time this document is executed.
5. The following amendments of the articles of incorporation of the corporation were adopted by the directors of the corporation on March 24, 1984, in the manner prescribed by the Florida Not for Profit Corporation Act.
6. The corporation has no shares authorized, issued, or outstanding.
7. The amendments substitute a revised legal description as Exhibit A to the Articles of Incorporation. The revised legal description is attached hereto as Exhibit A.

Dated: March 24, 1984

RIVER RUN OF SEBASTIAN  
CONDOMINIUM ASSOCIATION, INC.

by: *Henry J. Mull*  
President

attest: *Henry J. Mull*  
Secretary

COPY

STATE OF FLORIDA  
COUNTY OF INDIAN RIVER

Before me, the undersigned authority duly authorized in the state and county aforesaid to take acknowledgments, appeared HENRY J. MULLER and CECELIA Z. MULLER, known to me and known to me to be the President and Secretary, respectively, of RIVER RUN OF SEBASTIAN CONDOMINIUM ASSOCIATION, INC., and the persons described in and who executed the foregoing Articles of Amendment to Articles of Incorporation, and they acknowledged before me that they had executed the same.

Witness my hand and official seal at Vero Beach, Florida, this 27th day of March, 1984.

*Debra J. Johnson*  
Notary Public State  
of Florida at Large.

My Commission Expires:

(Seal)

NOTARY PUBLIC STATE OF FLORIDA AT LARGE  
MY COMMISSION EXPIRES OCT. 23, 1985  
BONDED THRU GENERAL INS. UNDERWRITERS

COPY

COPY

O. R. 0764 PG 0395

EXHIBIT A

Portions of Government Lots 3 and 4, Section 8, Township 31 South, Range 39 East, Indian River County, Florida, more particularly described as follows:

Commencing at the Southwest corner of aforementioned Government Lot 4, run South  $89^{\circ}38'22''$  East, along the South line of said Government Lot 4, also being the South Section line, 84.96 feet to the East right-of-way of State Road No. 5 (U.S. Highway No. 1); thence North  $25^{\circ}57'59''$  West along said right-of-way, 39.01 feet to the Point of Beginning. From the Point of Beginning, continue North  $25^{\circ}57'59''$  West, along said East right-of-way 154.21 feet to its intersection with the East line of aforementioned Government Lot 3; thence continue North  $25^{\circ}57'59''$  West along said right-of-way in Government Lot 3, 394.11 feet to the South line of Floravon Shores Subdivision, as recorded in Plat Book 4, page 78, Public Records of Indian River County, Florida; thence leaving State Road No. 5 right-of-way, run North  $88^{\circ}20'31''$  East along the South line of said Floravon Shores, 173.38 feet to its intersection with the East line of Government Lot 3; thence continue North  $88^{\circ}20'31''$  East, in Government Lot 4, 1,070 feet, more or less, to the Westerly shore of the Indian River; thence meander Southeasterly along the shore of the Indian River 720 feet, more or less, to its intersection with a line which bears South  $89^{\circ}38'22''$  East from the Point of Beginning and is 35 feet North of and parallel with the South line of Government Lot 4; thence North  $89^{\circ}38'22''$  West, 1,300 feet along said line, parallel with the South line of Government Lot 4 to the Point of Beginning.

ALSO BEING DESCRIBED AS:

That part of Government Lot 3, lying East of U.S. Highway No. 1, as now located, and all of Government Lot 4, Section 8, Township 31 South, Range 39 East, Indian River County, Florida, less and except parcels described in Deed Book 85, page 63 and Deed Book 102, page 406, Public Records of Indian River County, Florida and also, less the South 35 feet of said Government Lot 4.

LESS THE FOLLOWING DESCRIBED PARCELS:

Commencing at the Southwest corner of the aforementioned Government Lot 4, run South  $89^{\circ}38'22''$  East along the South line of said Government Lot 4, also being the South Section line, 84.96 feet to the East right-of-way of State Road No. 5 (U.S. Highway No. 1); thence North  $25^{\circ}57'59''$  West along said right-of-way, 126.01 feet; thence North  $64^{\circ}02'01''$  East, 25.0 feet to the Point of Beginning. From the Point of Beginning, run North  $41^{\circ}54'47''$  East, 114.84 feet; thence South  $52^{\circ}46'11''$  East, 200.0 feet; thence South  $0^{\circ}21'38''$  West, 40.0 feet; thence North  $89^{\circ}38'22''$  West, 199.53 feet; thence North  $25^{\circ}57'59''$  West, 82.63 feet to the Point of Beginning.

AND ALSO EXCEPTING:

Commencing at the Southwest corner of the aforementioned Government Lot 4, run South  $89^{\circ}38'22''$  East along the South line of said Government Lot 4, also being the South Section line, 84.96 feet to the East right-of-way of State Road No. 5 (U.S. Highway No. 1); thence North  $25^{\circ}57'59''$  West, along said right-of-way, 226.01 feet; thence North  $64^{\circ}02'01''$  East 25.0 feet to the Point of Beginning. From the Point of Beginning, run North  $25^{\circ}57'59''$  West, 165.0 feet; thence North  $64^{\circ}02'01''$  East, 125.0 feet; thence South  $25^{\circ}57'59''$  East, 145.0 feet; thence South  $25^{\circ}22'20''$  West, 32.02 feet; thence South  $64^{\circ}02'01''$  West, 100.0 feet to the Point of Beginning.



Department of State

I certify that the attached is a true and correct copy of the Articles of Amendment, filed on March 18, 1985, to Articles of Incorporation for RIVER RUN OF SEBASTIAN CONDOMINIUM ASSOCIATION, INC., a Florida corporation, as shown by the records of this office.

The charter number of this corporation is N01637.

Given under my hand and the Great Seal of the State of Florida, at Tallahassee, the Capital, this the 18th day of March, 1985.



CER-101

George Firestone  
Secretary of State

BOOK 0711 PAGE 1142

O.R. 797 PG 0404

O.R. 0764 PG 0397

**ARTICLES OF AMENDMENT TO THE  
ARTICLES OF INCORPORATION OF**

**River Run of Sebastian Condominium Association, Inc.**

**FILED**  
**MAR 18 10 06 AM '85**  
**SECRETARY OF STATE**  
**TALLAHASSEE, FLORIDA**

To: Department of State  
Tallahassee, Florida 32301

Pursuant to the provisions of Section 607.187 and 617.017 of the Florida Statutes, the undersigned corporation adopts the following articles of amendment to its articles of incorporation:

1. The name of the corporation is RIVER RUN OF SEBASTIAN CONDOMINIUM ASSOCIATION, INC.

2. The corporation is a not-for-profit corporation organized under Florida law in 1984.

3. The articles of incorporation of the corporation do not contain express provisions governing the manner in which amendments to the said articles are to be adopted.

4. The corporation has three (3) members at the time this document is executed. Pursuant to the provisions of Florida Statute 617.017(3), all directors, managers, trustees, and members eligible to vote have signed a written statement manifesting their intention that two amendments to the articles of incorporation be adopted, and that these particular amendments be adopted.

5. The following amendments of the articles of incorporation of the corporation were adopted by the directors, managers, trustees and members eligible to vote on March 5, 1985, in the manner provided for in the Florida Not for Profit Corporation Act.

a. Article III, Section 2, of the Articles of Incorporation is amended by adding thereto a new Subsection "m" the text of which is as follows:

"m. To own and/or operate and maintain docking facilities for the use of members, and all such peripheral facilities necessary or desirable in connection with the operation and maintenance of same, provided, however, that such docking facilities, if added by the Developer, shall contain a number of boat slips smaller than the total number of condominium units in all of the condominiums to be operated by the Association, and therefore shall be for the use and enjoyment solely of those unit owners who otherwise qualify for the use

BOOK 0711 PAGE 1143

O.R. 797 PG 0405

O.R. 0764 PG 0308



COPY

thereof, and provided, further, that anything in these Articles of Incorporation to the contrary notwithstanding, all expenses of operation and maintenance of such docking facilities shall be borne solely by those unit owners in the condominiums administered by the Association who have the right to use the boat slips therein."

b. The present Subsection "m" of Section 2 of Article III of the Articles of Incorporation shall be relettered as Subsection "n", and Subsection "n" as Subsection "o".

c. The legal description originally attached to the Articles of Incorporation as Exhibit AI-A and Exhibit A attached in its place by Amendment dated March 24, 1984, are hereby deleted and there is hereby substituted in their place a new Exhibit AI-A attached hereto and made a part hereof as Exhibit AI-A.

6. The corporation has no shares authorized, issued, or outstanding.

Dated: March 12, 1985

RIVER RUN OF SEBASTIAN  
CONDOMINIUM ASSOCIATION, INC.

by: Henry J. Muller  
Henry J. Muller, President

attest: Cecelia Z. Muller  
Cecelia Z. Muller, Secretary

(Corporate Seal)

STATE OF FLORIDA  
COUNTY OF INDIAN RIVER

BEFORE ME, the undersigned authority, duly authorized to take acknowledgments in the aforesaid state and county, appeared HENRY J. MULLER and CECELIA Z. MULLER, the President and Secretary, respectively, of RIVER RUN OF SEBASTIAN CONDOMINIUM ASSOCIATION, INC., and they acknowledged before me that they executed the foregoing Articles of Amendment in their corporate capacities.



BOOK 0711 PAGE 1144

O.R. 797 PG 0406

O.R. 0764 PG 0399

having been duly authorized to do so.

WITNESS MY HAND and official seal this 12th day of March, 1985.

COPY

*[Handwritten Signature]*

Notary Public, State of Florida  
at Large. My Commission Expires:

(Seal)

NOTARY PUBLIC STATE OF FLORIDA AT LARGE  
MY COMMISSION EXPIRES OCT. 23, 1985  
BONDED THRU GENERAL INS. UNDERWRITERS

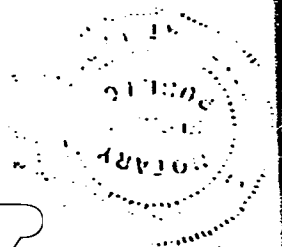

COPY

COPY

BOOK 0711 PAGE 1145

O.R. 0764 PG 0400

O.R. 797 PG 0407

EXHIBIT AI-A

Portions of Government Lots 3 and 4, Section 8, Township 31 South, Range 39 East, Indian River County, Florida, more particularly described as follows:

Commencing at the Southwest corner of aforementioned Government Lot 4, run South  $89^{\circ}38'22''$  East, along the South line of said Government Lot 4, also being the South Section line, 84.96 feet to the East right-of-way of State Road No. 5 (U.S. Highway No. 1); thence North  $25^{\circ}57'59''$  West along said right-of-way, 39.01 feet to the Point of Beginning. From the Point of Beginning, continue North  $25^{\circ}57'59''$  West, along said East right-of-way 154.21 feet to its intersection with the East line of aforementioned Government Lot 3; thence continue North  $25^{\circ}57'59''$  West along said right-of-way in Government Lot 3, 394.11 feet to the South line of Floravon Shores Subdivision, as recorded in Plat Book 4, page 78, Public Records of Indian River County, Florida; thence leaving State Road No. 5 right-of-way, run North  $38^{\circ}20'31''$  East along the South line of said Floravon Shores, 173.38 feet to its intersection with the East line of Government Lot 3; thence continue North  $88^{\circ}20'31''$  East, in Government Lot 4, 1,070 feet, more or less, to the Westerly shore of the Indian River; thence meander Southeasterly along the shore of the Indian River 720 feet, more or less, to its intersection with a line which bears South  $89^{\circ}38'22''$  East from the Point of Beginning and is 35 feet North of and parallel with the South line of Government Lot 4; thence North  $89^{\circ}38'22''$  West, 1,300 feet along said line, parallel with the South line of Government Lot 4 to the Point of Beginning.

ALSO BEING DESCRIBED AS:

That part of Government Lot 3, lying East of U.S. Highway No. 1, as now located, and all of Government Lot 4, Section 8, Township 31 South, Range 39 East, Indian River County, Florida, less and except parcels described in Deed Book 85, page 61 and Deed Book 102, page 406, Public Records of Indian River County, Florida and also, less the South 35 feet of said Government Lot 4.

BOTH OF THE FOREGOING TWO (2) DESCRIPTIONS BEING LESS THE FOLLOWING TWO (2) DESCRIBED PARCELS:

Parcel 1: Commencing at the Southwest corner of the aforementioned Government Lot 4, run South  $89^{\circ}38'22''$  East along the South line of said Government Lot 4, also being the South Section line, 84.96 feet to the East right-of-way of State Road No. 5 (U.S. Highway No. 1); thence North  $25^{\circ}57'59''$  West along said right-of-way, 126.01 feet; thence North  $64^{\circ}02'01''$  East, 25.0 feet to the Point of Beginning. From the Point of Beginning, run North  $41^{\circ}54'47''$  East, 114.84 feet; thence South  $52^{\circ}46'11''$  East, 200.0 feet; thence South  $0^{\circ}21'38''$  West, 40.0 feet; thence North  $89^{\circ}38'22''$  West, 199.53 feet; thence North  $25^{\circ}57'59''$  West, 82.63 feet to the Point of Beginning.

AND ALSO EXCEPTING:

Parcel 2: Commencing at the Southwest corner of the aforementioned Government Lot 4, run South  $89^{\circ}38'22''$  East along the South line of said Government Lot 4, also being the South Section line, 84.96 feet to the East right-of-way of State Road No. 5 (U.S. Highway No. 1); thence North  $25^{\circ}57'59''$  West, along said right-of-way, 226.01 feet; thence North  $64^{\circ}02'01''$  East 25.0 feet to the Point of Beginning. From the Point of Beginning, run North  $25^{\circ}57'59''$  West, 165.0 feet; thence North  $64^{\circ}02'01''$  East, 125.0 feet; thence South  $25^{\circ}57'59''$  East, 145.0 feet; thence South  $25^{\circ}22'20''$  West, 32.02 feet; thence South  $64^{\circ}02'01''$  West, 100.0 feet to the Point of Beginning.

BY-LAWS

OF

RIVER RUN OF SEBASTIAN CONDOMINIUM ASSOCIATION, INC.

1. IDENTITY

These are the By-laws of RIVER RUN OF SEBASTIAN CONDOMINIUM ASSOCIATION, INC., a corporation not for profit organized under the laws of the State of Florida, the Articles of Incorporation of which were filed in the office of the Secretary of State on February 24, 1984. River Run of Sebastian Condominium Association, Inc., hereinafter called "Association", has been organized for the purpose of administering the operation and management of the condominiums (the "Condominiums") to be established by MULLER ENTERPRISES, INC., a Florida corporation, and its successors and assigns hereinafter sometimes called, "Developer", upon lands owned by it and as described in Article II of said Articles of Incorporation (the "Land").

a. The provisions of these By-laws are applicable to the Condominiums and the terms and provisions hereof are expressly subject to the terms and provisions of the Articles of Incorporation of the Association and to those which may be contained in the Declarations of Condominium which may be recorded for the Condominiums in the Public Records of Indian River County, Florida, the terms and provisions of such Articles of Incorporation and such Declarations of Condominium to be controlling wherever the same may be in conflict herewith.

b. All present or future owners, tenants, future tenants or their employees or any other person who might use the Condominiums, or any of the facilities thereof in any manner, are subject to the regulations set forth in these By-laws and in said Articles of Incorporation and the applicable Declaration of Condominium.

c. The office of the Association shall initially be at 3426 Ocean Drive, Vero Beach, Indian River County, Florida.

d. The fiscal year of the Association shall be the calendar year, January 1 through December 31.

e. The seal of the Association shall bear the name of the Association, the word "Florida", the words "Corporation Not For Profit", and the year of incorporation, an impression of which seal is as follows:

2. MEMBERSHIP, VOTING, QUORUM, PROXIES

a. Membership. The qualification of members, the manner of their admission to membership and termination of such membership, and voting by members shall be as set forth in Article IV of the Articles of Incorporation of the Association, the provisions of which said Article IV of the Articles of Incorporation are incorporated herein by reference.

b. Quorum. A quorum at members' meetings shall be attained by the presence, either in person or by proxy, of persons entitled to cast 33 1/3% of the votes of the entire membership. If voting rights of any member are suspended pursuant to the provisions of the Declarations of Condominium, these By-laws, or applicable rules and regulations, the votes of such member so suspended shall not be counted for the purpose of determining the presence of a quorum and the total number of authorized votes

Exhibit H

O.R. 797 PG 0409

BOOK 0711 PAGE 1147

O.R. 9764 PG 0402

shall be reduced accordingly during the period of such suspension.

c. Majority Vote. The acts approved by a majority of the votes present in person or by proxy at a meeting at which a quorum shall have been attained shall be binding upon all Unit Owners for all purposes except where otherwise provided by law, the Declarations of Condominium, the Articles of Incorporation, or these By-laws, as used in these By-laws, the Articles of Incorporation or any of the Declarations of Condominium, the terms "majority of the Unit Owners" and "majority of the members" shall mean a majority of the votes of Unit Owners and not a majority of members themselves and shall further mean more than 50% of the then total authorized votes present in person or by proxy and voting at any meeting of the Unit Owners at which a quorum shall have been attained. Similarly, if some greater percentage of members is required herein or in the Articles of Incorporation or any of the Declarations of Condominium, it shall mean such greater percentage of the votes of members and not of the members themselves.

d. Voting Certificates. The vote of the owners of a Condominium unit owned by more than one person or by a corporation or other entity shall be cast by the person named in a certificate previously signed by all of the owners of the unit and filed with the Secretary of the Association, and such certificate shall be valid until revoked by the filing of a subsequent certificate. If such a certificate is not on file, the vote of such multiple or corporate owners shall not be considered in determining the requirement for a quorum, nor for any other purpose.

e. Proxies, Written Votes. Votes may be cast in person, by proxy, or in writing. However, a written vote can be only effective as to matters on which prior notice was given. Proxies and written votes shall be valid only for the particular meeting designated thereon and any lawful adjourned meetings thereof, and must be filed with the Secretary before the appointed time of the meeting or before the time to which the meeting is adjourned. Each proxy shall specifically set forth the name of the person voting by proxy, and the name of the person authorized to vote the proxy for him. In no event shall any proxy be valid for a period longer than 90 days after the date of the first meeting for which it was given. Each proxy shall contain the date, time and place of the meeting for which the proxy is given, and if a limited proxy, set forth those items which the holder of the proxy may vote, and the manner in which the vote is cast. Every proxy shall be revocable at any time at the pleasure of the Unit Owner executing it.

f. Authorized Voters. Approval or disapproval of a unit owner upon any matters, whether or not the subject of an Association meeting, shall be by the same person who would cast the vote of such owner if in an Association meeting.

### 3. ANNUAL AND SPECIAL MEETINGS OF MEMBERSHIP

a. Annual Meeting. The annual members' meeting shall be held on the date, at the place and at the time determined by the Board of Directors from time to time, provided that there shall be an annual meeting every calendar year, and to the extent possible no later than twelve (12) months after the preceding annual meeting, for the purpose of electing directors and of transacting any other business authorized to be transacted by the members; provided, however, that, if that day is a legal holiday, the meeting shall be held at the same hour on the next succeeding business day.

b. Special Meetings. Special members' meetings shall be held whenever called by the President or Vice President, or by a majority of the Board of Directors, and must be called by such officers upon receipt of a written request from members entitled

to cast twenty percent (20%) of the votes of the entire membership.

c. Notice of Meetings. Notice of all members' meetings, regular or special, shall be given by the President, Vice President or Secretary of the Association, or other officer of the Association in absence of said officers, to each member, unless waived in writing, such notice to be written or printed and to state the time and place and object for which the meeting is called. Such notice shall be given to each member not less than fourteen (14) days nor more than sixty (60) days prior to the date set for such meeting, which notice shall be mailed or presented personally to each member within said time and shall also be posted in a conspicuous place on the condominium property at least fourteen (14) days prior to the meeting. If presented personally, receipt of such notice shall be signed by the member, indicating the date on which such notice was received by him. If mailed, such notice shall be deemed to be properly given when deposited in the United States mail addressed to the member at his post office address as it appears on the records of the Association, the postage thereon prepaid. A post office certificate of mailing for each addressee shall be retained in the Association records as proof of such mailing. Any member may, by written waiver of notice signed by such member, waive such notice, and such waiver, when filed in the records of the Association, whether before or after the holding of the meeting, shall be deemed equivalent to the giving of such notice to such member. If any members' meeting cannot be organized because a quorum has not attended, or because the greater percentage of the membership required to constitute a quorum for particular purposes has not attended, wherever the latter percentage of attendance may be required as set forth in the Articles of Incorporation, these By-laws, the Declarations of Condominium or the Condominium Law, the members who are present, either in person or by proxy, may adjourn the meeting from time to time until a quorum, or the required percentage of attendance if greater than a quorum, is present.

d. Order of Business. The order of business at annual members' meeting and, as far as practical, at any other members' meeting, shall be:

- (i) Election of Chairman of the meeting
- (ii) Calling of the roll and certifying of proxies
- (iii) Proof of notice of meeting or waiver of notice
- (iv) Reading and disposal of any unapproved minutes
- (v) Reports of officers
- (vi) Reports of committees
- (vii) Election of directors
- (viii) Unfinished business
- (ix) New business
- (x) Adjournment

e. Proviso. Provided, however, that until such time as the Developer shall relinquish control of the Association to the Condominium unit owners other than Developer, the proceedings of any meetings of the members of the Association shall have no effect unless approved by the Board of Directors.

f. Action Without a Meeting (Members). Anything to the contrary herein, in the Articles of Incorporation, or in the several Declarations of Condominium to the contrary notwithstanding, to the extent lawful, any action required to be taken at any annual or special meeting of members, or any action which may be taken at any annual or special meeting of such members, may be taken without a meeting, without prior notice, and without a vote if a consent in writing, setting forth the action so taken, shall be signed by the members (or persons authorized to cast the vote of any such member as elsewhere herein set forth) having not less than the minimum number of votes that would be necessary to attain a quorum, or, with respect to certain matters where a higher percentage of members are required, such number of votes that would be necessary to approve such matters. Within

ten (10) days after obtaining such authorization by written consent, notice must be given to members who have not consented in writing. The notice shall fairly summarize the material features of the authorized action.

b. Minutes of Meetings. The minutes of all meetings of unit owners and of the Board of Directors as hereinafter set forth shall be kept in a book available for inspection by Unit Owners, or their authorized representatives, and board members at any reasonable time. The Association shall retain these minutes for a period of not less than seven (7) years.

#### 4. BOARD OF DIRECTORS

a. Management by Board. The first Board of Directors of the Association, and succeeding Boards of Directors shall manage the affairs of the Association. At least a majority of the Board of Directors shall be members of the Association, or shall be authorized representatives, officers or employees of a corporate member of the Association; provided that members of the Board of Directors designated by the Developer, as hereinafter provided, need not be members of the Association. Whenever Developer shall be entitled to designate and select any person or persons to serve on any Board of Directors of the Association, Developer, or Developer's successors or assigns, shall have the right to remove any person or persons to act and serve in the place of any director or directors so removed for the remainder of the unexpired term of any director or directors so removed. Any director designated and selected by Developer need not be a resident in the Condominiums or a member of Association.

b. Election of Board. Election of directors shall be conducted in the following manner:

(i) Developer shall, at the beginning of the election of the Board of Directors, designate and select that number of the members of the Board of Directors which it shall be entitled to designate and select in accordance with the provisions of these By-laws, and upon such designation and selection by Developer by written instrument presented to the meeting at which such election is held, said individuals so designated and selected by Developer shall be deemed and considered for all purposes directors of the Association, and shall thenceforth perform the offices and duties of such directors until their successors shall have been selected or elected in accordance with the provisions of these By-laws. Should Developer fail to designate and select members of the Board of Directors at any time while the said Developer is entitled to designate and select members of the Board of Directors as herein provided, those members of the Board of Directors previously designated and selected by Developer shall continue to serve as members of the Board of Directors as though designated and selected as herein provided.

(ii) All members of the Board of Directors whom Developer shall not be entitled to designate and select under the terms and provisions of these By-laws or the Articles of Incorporation shall be elected by a plurality of the votes cast at each annual meeting of the members of the Association or at such other members' meetings as are provided for in Article VIII of the Articles of Incorporation.

(iii) Vacancies in the Board of Directors may be filled until the date of the next annual meeting by the remaining directors, except that should any vacancy in the Board of Directors be created in any directorship previously filled by any person designated and selected by Developer, such vacancy shall be filled by Developer's designating and selecting, by written instrument delivered to any officer of the Association, the successor Director to fill the vacated directorship for the unexpired term thereof.

(iv) In the election of directors, there shall be appurtenant to each unit as many votes for directors as there are directors to be elected; provided, however, that no member or owner may cast more than one vote per unit owned for any person nominated as a director, it being the intent hereof that voting for directors shall be non-cumulative.

(v) In the event that Developer, in accordance with the privilege granted unto it, selects any person or persons to serve on any Board of Directors of the Association, the said Developer shall have the absolute right at any time, in its sole discretion, to replace any such person or persons with another person or persons selected by Developer to serve on said Board of Directors. Replacement of any person or persons selected by Developer to serve on the Board of Directors of the Association shall be made by written instrument delivered to any officer of the Association, which instrument shall specify the name or names of the person or persons designated as successor or successors to the persons so removed from said Board of Directors. The removal of any director and designation of his successor shall be effective immediately upon delivery of such written instrument by Developer to any officer of the Association.

c. Organizational Meeting. The organizational meeting of a newly elected Board of Directors shall be held within ten (10) days of their election, at such time and at such place as shall be fixed by the directors at the meeting at which they were elected, and no further notice of the organizational meeting shall be necessary provided a quorum shall be present.

d. Regular Meetings, Notice. Regular meetings of the Board of Directors may be held at such time and place as shall be determined from time to time by a majority of the directors. Notice of regular meetings shall be given to each director, personally or by mail, telephone or mailgram at least three (3) days prior to the day named for such meeting, unless notice is waived.

e. Special Meetings. Special meetings of the directors may be called by the President, and must be called by the Secretary at the written request of one-third (1/3) of the votes of the Board. Not less than ten (10) days' notice of a meeting shall be given to each director personally or by mail, telephone or telegram, which notice shall state the time, place and purpose of the meeting.

f. Notice to Unit Owners. Adequate notice of all meetings (including adjournments) of the Board of Directors shall be posted conspicuously on the property of each condominium, at least forty-eight (48) hours in advance of each meeting, except where a meeting of the Board of Directors is held to deal with an emergency. Notice of any meeting at which assessments against unit owners are to be considered for any reason shall specifically contain a statement that assessments will be considered and the nature of any such assessments.

g. Attendance of Unit Owners. Unit owners shall have the right to attend and observe all meetings of the Board of Directors. If the Board of Directors meets using telephone conference equipment, a telephone speaker shall be attached so that the discussion may be heard by the board members and by any unit owners present in an open meeting.

h. Waiver of Notice. Any director may waive notice of a meeting before or after the meeting, and such waiver shall be deemed equivalent to the giving of notice.

i. Quorum. A quorum at a directors' meeting shall consist of the directors entitled to cast a majority of the votes of the entire Board. The acts of the Board approved by a majority of the votes present at the meeting at which a quorum is present, shall constitute the acts of the Board of Directors, except as

11/15/1



specifically otherwise provided in the Articles of Incorporation, these By-laws or the Declarations of Condominium. If any directors' meeting cannot be organized because a quorum has not attended, or because the greater percentage of directors required to constitute a quorum for particular purposes has not attended, wherever the latter percentage of attendance may be required as set forth in the Articles of Incorporation, these By-laws or the Declarations of Condominium or the Condominium Law, the directors who are present may adjourn the meeting from time to time until a quorum, or the required percentage of attendance if greater than a quorum, is present. At any adjourned meeting, any business which might have been transacted at the meeting as originally called may be transacted.

**j. Presiding Officer.** The presiding officer of directors' meeting shall be Chairman of the Board, if such an officer has been elected; and if none, then the President shall preside. In the absence of the presiding officer, the directors present shall designate one of their number to preside.

**k. Directors' Fees.** Directors' fees, if any, shall be determined by the members.

**l. Powers of Board.** All of the powers and duties of the Association shall be exercised by the Board of Directors, including those existing under the common law and statutes, the Articles of Incorporation of the Association, these By-laws and the Declarations of Condominium. Such powers and duties shall be exercised in accordance with said common law and statutes, the Articles of Incorporation, these By-laws and the Declarations of Condominium, and shall include, without limiting the generality of the foregoing, the following:

(i) To make, levy and collect assessments against members and members' units to defray the cost of operation of the Condominiums established by Developer on the Lands, and to use the proceeds of said assessments in the exercise of the powers and duties granted unto the Association.

(ii) The maintenance, repair, replacement, operation and management of the Condominiums wherever the same is required to be done and accomplished by the Association for the benefit of its members.

(iii) The reconstruction of improvements after casualty and the further improvement of the property, real and personal.

(iv) To make and amend regulations governing the use of the property, real and personal, in, on or about the Condominiums, so long as such regulations or amendments thereto do not conflict with the restrictions and limitations which may be placed upon the use of such property under the terms of the Articles of Incorporation and Declarations of Condominium.

(v) To approve and disapprove proposed purchasers and lessees of units in the manner specified in the Declarations of Condominium.

(vi) To acquire, operate, lease, manage and otherwise trade and deal with property, real and personal, including units in the Condominiums, as may be necessary or convenient in the operation and management of the Condominiums, and in accomplishing the purposes set forth in the Declarations of Condominium.

(vii) To contract with respect to the exercise of its powers and for the management of the Condominiums, and to delegate to such contractor all of the powers and duties of the Association, except those which may be required by the Declarations of Condominium to have approval of the Board of Directors or membership of the Association.

(viii) To enforce by legal means the provisions of the Articles of Incorporation and By-laws of the Association, the Declarations of Condominium and the regulations hereinafter promulgated governing use of the property in the Condominiums.

(ix) To pay all taxes and assessments which are liens against any part of the Condominiums other than units and the appurtenances thereto, and to assess the same against the members and their respective units subject to such liens.

(x) To carry insurance for the protection of the members and the Association against casualty and liability.

(xi) To pay all costs of power, water, sewer and other utility services rendered to the Condominiums and not billed to the owners of the separate units within the Condominiums, and to comply with and enforce all contracts relating to the supply of such utility services.

(xii) To pay all costs associated with the operation and maintenance of docking facilities located on or adjacent to its property or the property of its constituent condominiums, and to assess for such costs all owners of units in such constituent condominiums who have the right to use the docking facilities, as well as to make and enforce rules and regulations for the use thereof.

**m. First Board.** The first Board of Directors of the Association shall be comprised of the three (3) persons designated to act and serve as directors in the Articles of Incorporation, which said persons shall serve until their successors are designated or elected as provided in Article VIII of the Articles of Incorporation; provided, however, that any election of directors shall be subject to all of the rights hereinabove reserved to Developer by section 4(a) of these By-laws.

**n. Contracts of First Board.** The undertakings and contracts authorized by said first Board of Directors shall be binding upon the Association in the same manner as though such undertakings and contracts had been authorized by the first Board of Directors duly elected by the membership, so long as any undertakings and contracts are within the scope of the powers and duties which may be exercised by the Board of Directors of the Association in accordance with all applicable Condominium documents and the Condominium law.

**o. Removal of Directors.** Any one or more of the directors of the Board of Directors of the Association may be recalled and removed from office with or without cause by the vote or agreement in writing of a majority of all the voting interests; provided, however, that only Developer shall have the right to remove a director appointed by it. A special meeting of the unit owners to recall a member or members of the Board of Directors may be called by 10 percent or more of the voting interests giving notice of the meeting as required for a meeting of unit owners, and the notice shall state the purpose of the meeting.

(1) If the recall is approved by a majority of all voting interests by a vote at a meeting, the recall shall be effective immediately, and the recalled member or members of the Board of Directors shall turn over to the Board of Directors any and all records of the Association in their possession, within 72 hours after the meeting.

(ii) If the proposed recall is by an agreement in writing by a majority of all voting interests, the agreement in writing shall be served on the Association by certified mail. The Board of Directors shall call a meeting of the Board within 72 hours after receipt of the agreement in writing and shall either certify the written agreement to recall a member or members of the Board, in which case such member or members shall be recalled effective immediately and shall turn over to the

Board within 72 hours, any and all records of the Association in their possession, or proceed as described in subparagraph (iii).

(iii) If the Board determines not to certify the written agreement to recall a member or members of the Board, or if the recall by a vote at a meeting is disputed, the Board shall, within 72 hours, file with the Division of Florida Land Sales, Condominiums and Mobile Homes a petition for binding arbitration pursuant to the procedures of Section 718.1255, Florida Statutes 1984. For purposes of this section, the unit owners who voted at the meeting or who executed the agreement in writing shall constitute one party under the petition for arbitration. If the arbitrator certifies the recall as to any member or members of the Board, the recall shall be effective upon service of the final order of arbitration upon the Association. If the Association fails to comply with the order of the arbitrator, the aforesaid division may take action pursuant to Section 718.501, Florida Statutes 1984. Any member or members of the Board of Directors so recalled shall deliver to the Board any and all records of the Association in their possession within 72 hours of the effective date of the recall.

p. Adoption of Budgets. The Board of Directors shall mail a meeting notice and copies of the proposed annual budget(s) of common expenses to the unit owners not less than fourteen (14) days prior to the meeting at which the budget will be considered. The meeting notice shall contain information as to the time and place of the meeting of the Board of Directors to be held to consider the budget(s). Such meeting shall be open to Unit Owners. If an adopted budget requires assessment against Unit Owners in any fiscal or calendar year exceeding 115 percent of the assessments for the preceding year, the Board of Directors, upon written application of ten percent or more of the voting interests shall call a special meeting of the Unit Owners within thirty (30) days, upon not less than ten (10) days' written notice to each Unit Owner. At the special meeting, Unit Owners shall consider and pass upon the budget submitted to them. The adoption of such a budget at such a meeting shall require a vote of not less than a majority of all voting interests present in person or by proxy. The Board of Directors may propose a budget or budgets to the Unit Owners at a meeting of members or in writing, and if the proposed budget(s) are approved by the Unit Owners at the meeting or by a majority of all Unit Owners in writing, the budget(s) shall be adopted. If a meeting of the Unit Owners has been called and a quorum is not attained or a substitute budget is not adopted by the Unit Owners, the budget adopted by the Board of Directors shall go into effect as scheduled. In determining whether assessments exceed 115 percent of similar assessments in prior years, any authorized provisions for reasonable reserves for repair or replacement of the condominium property, anticipated expenses by the Association which are not anticipated to be incurred on a regular or annual basis, or assessments for betterments to the condominium property shall be excluded from the computation. However, as long as the Developer is in control of the Board of Directors, the Board of Directors shall not impose a budget or budgets requiring assessments for any year greater than 115 percent of the prior fiscal or calendar year's assessments without approval of a majority of all voting interests.

q. Action Without a Meeting (Directors). Anything herein or in the Articles of Incorporation or Declarations of Condominium to the contrary notwithstanding, and to the extent lawful, any action required to be taken at a meeting of the Board of Directors, or any action which may be taken at a meeting of the Board of Directors or any committee thereof, may be taken without a meeting if a consent in writing setting forth the action so to be taken signed by all of the Directors or all of the members of the committee, as the case may be, is filed in the minutes of the proceedings of the Board of Directors or of the committee. Such consent shall have the same effect as a unanimous vote. No prior notice of such intended action shall be required to be given to

the Directors or to the Unit Owners. Notice of the taking of such action shall, however, be posted conspicuously on the condominium property for the attention of Unit Owners after such action shall have been effected. Such notice shall fairly summarize the material features of the action so taken.

r. Presumption of Assent. A director of the Association who is present at a meeting of its Board at which action on any corporate matter is taken shall be presumed to have assented to the action taken, unless he votes against such action or abstains from voting in respect thereto because of an asserted conflict of interest.

## 5. OFFICERS

a. Executive Officers. The executive officers of the Association shall be a President, who shall be a director, a Treasurer, a Secretary and such other assistants or vice officers as the Board of Directors may determine, all of whom shall be elected annually by the Board of Directors and who may be peremptorily removed by vote of the directors at any meeting. Any person may hold two or more offices, except that the President shall not also be the Secretary or an Assistant Secretary. The Board of Directors shall from time to time elect such other officers and designate their powers and duties as the Board shall find to be required to manage the affairs of the Association.

b. President. The President shall be the chief executive officer of the Association. He shall have all of the powers and duties which are usually vested in the office of President of an association, including but not limited to the power to appoint committees from among the members from time to time, as he may in his discretion determine appropriate, to assist in the conduct of the affairs of the Association.

c. Secretary. The Secretary shall keep the minutes of all proceedings of the directors and the members. He shall attend to the giving and serving of all notices to the members and directors, and such other notices required by law. He shall have the custody of the seal of the Association and affix the same to instruments requiring a seal when duly signed. He shall keep the records of the Association, except those of the Treasurer, and shall perform all other duties incident to the office of Secretary of an Association and as may be required by the directors or President.

d. Treasurer. The Treasurer shall have custody of all of the property of the Association, including funds, securities and evidences of indebtedness. He shall keep the assessment rolls and accounts of the members; he shall keep the books of the Association in accordance with good accounting practices; and he shall perform all other duties incident to the office of Treasurer.

e. Compensation. The compensation, if any, of all officers and employees of the Association shall be fixed by the directors. This provision shall not preclude the Board of Directors from employing a director as an employee of the Association nor preclude the contracting with a director for the management of the Condominiums.

## 6. FISCAL MANAGEMENT.

The separate Condominiums established by the Developer upon the Lands will, in fiscal matters, be managed as separate entities and separate accounts shall be maintained for each of the separate condominiums and for the Association itself. The cost and expense of maintenance, upkeep, etc., for any Additional Facilities as described in paragraph 12 of the several Declarations of Condominium, any recreational facilities (including one or more pools), and any roadway or roadways for access to and from public ways, shall be assessed against each individual

Condominium unit for which the Association has operating responsibilities for its pro-rata share of such cost and expense based upon the number of units in each of said condominiums as that number bears to the total number of units in all Condominiums established and operated by the Association, and such assessed expenses shall be considered general common expenses of the Condominium so assessed. Such fiscal management will be as set forth in the several Declarations of Condominium, supplemented by the following:

a. Accounts. The receipts and expenditures of each separate Condominium and for the Association itself will be credited and charged to accounts pursuant to the expense classifications as follows, including, if applicable, but not limited to those expenses listed in Section 718.504(20), Fla. Stats., 1983, all of which expenditures shall be deemed common expenses:

(i) Current Expense, which will include all receipts and expenditures within the year for which the budget is made including a reasonable allowance for contingencies and working funds, except expenditures chargeable to reserves or to additional improvements. The balance in this fund at the end of each year will be applied to reduce assessments for current expenses for the succeeding year.

(ii) Reserves for deferred maintenance, which will include funds for maintenance items that occur less frequently than annually, including but not limited to, accounts for roof replacement, building painting and pavement resurfacing.

(iii) Reserves for replacement, which will include funds for repair or replacement required because of damage, depreciation or obsolescence.

(iv) Improvements, which will include funds to be used for capital expenditures for additions, including personal property, that will become part of the common property.

b. Budget. As provided in Section D. of Article 4 hereof the Board of Directors or the Unit Owners will adopt a budget for each Condominium and for the Association for each calendar year that will include the estimated funds required to defray current expenditures and to provide and maintain funds for the above accounts and reserves, according to good accounting practices, as follows:

(i) Current expense.

(ii) Reserves for deferred maintenance, except as otherwise provided by law, the amount for which will not exceed one hundred fifteen percent (115%) of the budget for this account for the prior year, once an initial reserve is established.

(iii) Reserves for replacement, except as otherwise provided by law, the amount for which will not exceed one hundred fifteen percent (115%) of the budget for this account for the prior year, once an initial reserve is established.

(iv) The initial reserves to be established shall be computed by means of a formula which is based upon estimated life and estimated replacement cost of each reserve item, except that the members by a majority vote at a duly called meeting of the Association may elect for a calendar year to provide no reserves or reserves less adequate than required by said formula.

c. Financial Report. Within ninety (90) days following the end of the Association's calendar year, the Board of Directors shall furnish to each unit owner a complete financial report of actual receipts and expenditures for the preceding year. The report shall show the amounts of receipts and expenses by corresponding accounts and classifications including, where appropriate, at least the following:

- (i) Cost for security;
- (ii) Professional and management fees and expenses;
- (iii) Taxes;
- (iv) Cost for recreational facilities;
- (v) Expenses for refuse collection and utility services;
- (vi) Expenses for lawn care;
- (vii) Cost for building maintenance and repair;
- (viii) Insurance costs;
- (ix) Administrative and salary expenses;
- (x) General reserves, maintenance reserves and depreciation reserves;
- (xi) Costs and expenses of any sewage disposal system; and
- (xii) Costs and expenses of any roadways for access to and from public ways.

d. Assessments. Assessments against the units for their shares of the items of the budgets will be made for the calendar year annually in advance on or before December 20 preceding the year for which the assessments are made. Such assessments will be due in four equal installments on the first day of January, April, July and October of the year for which the assessments are made. If an annual assessment is not made as required, an assessment will be presumed to have been made in the amount of the last prior assessment and quarterly installments will be due upon each payment date until changed by an amended assessment. In the event the annual assessment proves to be insufficient, the budgets and assessments may be amended at any time by the Board of Directors up to the limitations for that year. Any account that exceeds such limitations will be subject to the approval of the membership as previously required by these By-laws. The unpaid assessment for the remaining portion of the calendar year for which the amended assessment is made will be due in equal monthly installments on the first day of each month remaining in the year for which the assessment is due.

e. Acceleration of assessment installments upon default. If a unit owner shall be in default in the payment of an installment upon an assessment, the Board of Directors may accelerate the remaining installments of the assessment upon notice to the unit owner, and then the unpaid balance of the assessment will come due upon the date stated in the notice, but not less than ten (10) days after delivery of the notice to the unit owner, or not less than twenty (20) days after the mailing of such notice to him by registered or certified mail, whichever shall first occur; provided, however, that under no circumstances shall assessments be made less frequently than four (4) times per year.

f. Special Assessments. Special assessments, for emergencies, public assessments or otherwise, may be made by the Board of Directors from time to time to meet other needs or requirements of the Association in the operation and management of the Condominium or the Additional Facilities and to provide for emergencies, repairs or replacements, and infrequently recurring items of maintenance, or to perform any other function or act authorized expressly or impliedly by the applicable Declaration of Condominium, the Articles of Incorporation of the Association or these bylaws. The specific purpose or purposes of any special assessment shall be set forth in a written notice of such assessment sent or delivered to each Unit Owner. The funds collected

pursuant to a special assessment shall be used only for the specific purpose or purposes set forth in such notice, or if not so used, then returned to the Unit Owners; provided, however, that upon completion of such specific purpose or purposes, any excess funds shall be considered common surplus.

g. The depository of the Association will be such bank or banks as shall be designated from time to time by the directors and in which the moneys of the Association will be deposited. Withdrawals of moneys from such accounts will be only by checks signed by such persons as are authorized by the directors.

h. An audit of the accounts of the Association shall be made annually, and a copy of the report shall be furnished to each member not later than April 1 of the year following the year for which the report is made.

i. Fidelity bonds shall be required by the Board of Directors from all persons serving as directors or officers of the Association. The amounts of such bonds shall be determined by the directors and the premiums paid by the Association.

j. Transfer Fees. The Association shall be empowered to charge, by rule or regulation adopted by the Association, a transfer fee in connection with any sale, mortgage, lease, sublease or other transfer of a unit; provided, however, that no such fee may be charged unless the Association is required to approve such transfer. The fee shall be Fifty (\$50.00) Dollars per transfer. However, if the transfer is the renewal of a lease or sublease with the same lessee or sublessee, no charge shall be made.

k. Fines. The Association, acting by and through the Board of Directors, may levy reasonable fines against a Unit for failure of the Unit Owner or its occupant, licensee or invitee to comply with any provision of the applicable declaration of condominium, these bylaws or the rules and regulations of the Association. No fine shall become a lien against a Unit. No fine shall exceed \$10.00 nor shall any fine be levied except after giving reasonable notice and opportunity for a hearing to the Unit Owner and, if applicable, his licensee or invitee.

l. Estoppel Certificates. Within 15 days after request by a Unit Owner or unit mortgagee, the Association shall provide a certificate stating all assessments and other moneys owed to the Association by the Unit Owner with respect to such Unit owned by the Unit Owner as may be designated by the Unit Owner. Any person other than the Unit Owner who relies upon such certificate shall be protected thereby.

## 7. PARLIAMENTARY RULES

Roberts' Rules of Order (latest edition) shall govern the conduct of corporate proceedings when not in conflict with the Articles of Incorporation and these By-laws or with the Statutes of the State of Florida.

## 8. AMENDMENTS TO BY-LAWS

Amendments to these By-laws shall be proposed and adopted in the following manner:

a. Amendment Proposals. Amendments to these By-laws may be proposed by the Board of Directors of the Association acting upon vote of the majority of the directors, or by more than twenty-five percent (25%) of members of the Association, whether meeting as members or by instrument in writing signed by them.

b. Meetings on Amendments. Upon any amendment or amendments to these By-laws being proposed by said Board of Directors or members, such proposed amendment or amendments shall be transmitted to the President of the Association, or other officer of

the Association in absence of the President, who shall thereupon call a special joint meeting of the members of the Board of Directors of the Association and the membership for a date not sooner than twenty (20) days nor later than sixty (60) days from receipt by such officer of the proposed amendment or amendments, and it shall be the duty of the Secretary to give to each member written or printed notice of such meeting in the same form and in the same manner as notice of the call of a special meeting of the members is required as herein set forth.

c. Approval of Amendments. In order for such amendment or amendments to become effective, the same must be approved by an affirmative vote of two-thirds (2/3) of the entire membership of the Board of Directors and by an affirmative vote of fifty percent (50%) of the members. Thereupon, such amendment or amendments to these By-laws shall be transcribed, certified by the President and Secretary of the Association, and a copy thereof shall be recorded in the public records of Indian River County, Florida within twenty (20) days from the date on which any amendment or amendments have been affirmatively approved by the directors and members.

d. Written Votes. At any meeting held to consider such amendment or amendments to the By-laws, the written vote of any member of the Association shall be recognized if such member is not in attendance at such meeting or represented thereat by proxy.

e. Manner of Amendment. No by-law shall be amended by reference to its title or number only. Proposals to amend existing by-laws shall contain the full text of the by-law(s) to be amended; new words shall be inserted in the text underlined, and words to be deleted shall be lined through with hyphens. However, if the proposed change is so extensive that this procedure would hinder, rather than assist, the understanding of the proposed amendment, it is not necessary to use underlining and hyphens as indicators of words added or deleted, but, instead, a notation must be inserted immediately preceding the proposed amendment in substantially the following language: "Substantial rewording of by-law. See by-law for present text." Nonmaterial errors or omissions in the by-law process shall not invalidate an otherwise properly promulgated amendment.

f. Consent of Developer. Notwithstanding the foregoing provisions of this Article 8, no amendment to these By-laws which shall abridge, amend or alter the right of Developer to designate and select members of each Board of Directors of the Association, as provided in Article 4 hereof, may be adopted or become effective without prior written consent of Developer; and, further provided that these By-laws may be amended by action of a majority of the Board of Directors of the Association without vote of the membership, so long as Developer shall have the right to designate and select members of each Board of Directors of the Association, as provided in Article 4 hereof, or until such time as Developer may have relinquished its right to designate and select members of each Board of Directors or may waive the provisions of this paragraph of these By-laws, by instrument in writing executed with the formalities of a deed.

## 9. OFFICIAL RECORDS

a. From the inception of the Association, the Association shall maintain a copy of each of the following, where applicable, which shall constitute the official records of the Association:

(1) The plans, permits, warranties and other items provided by the Developer pursuant to Section 718.301(4), Florida Statutes 1984;

(11) A photocopy of the recorded declaration of each condominium operated by the Association and all amendments thereto;



(iii) A photocopy of the recorded bylaws of the Association and all amendments thereto;

(iv) A certified copy of the Articles of Incorporation of the Association and all amendments thereto;

(v) A copy of the current rules of the Association;

(vi) A book or books containing the minutes of all meetings of the Association, of the Board of Directors and of Unit Owners, which minutes shall be retained for a period of not less than 7 years;

(vii) A current roster of all unit owners, their mailing addresses, unit identifications, voting certifications and if known, telephone numbers;

(viii) All current insurance policies of the Association and condominiums operated by the Association;

(ix) A current copy of any management agreement, lease or other contract to which the Association is a party or under which the Association or the unit owners have an obligation or responsibility;

(x) Bills of sale or transfer for all property owned by the Association;

(xi) Accounting records for the Association and separate accounting records for each condominium it operates, according to good accounting practices. All accounting records shall be maintained for a period of not less than 7 years. The accounting records shall include, but are not limited to:

(1) Accurate, itemized and detailed records of all receipts and expenditures.

(2) A current account and a monthly, bimonthly or quarterly statement of the account for each unit designating the name of the unit owner, the due date and amount of each assessment, the amount paid upon the account and the balance due.

(3) All audits, reviews, accounting statements and financial reports of the Association or condominiums.

(4) All contracts for work to be performed. Bids for work to be performed shall also be considered official records and shall be maintained for a period of 1 year.

(xii) Voting proxies, which shall be maintained for a period of 1 year from the date of the meeting for which the proxy was given.

(xiii) All rental records where the Association is acting as agent for the rental of condominium units.

b. The official records of the Association shall be maintained in the county in which the condominium is located.

c. The official records of the Association shall be open to inspection by any Association member or the authorized representative of such member at all reasonable times. Failure to permit inspection of the Association records as provided herein entitles any person prevailing in an enforcement action to recover reasonable attorneys' fees from the person in control of the records who, directly or indirectly, knowingly denies access to the records for inspection. The right to inspect the records includes the right to make or obtain copies, at the reasonable expense, if any, of the Association member.

The foregoing were adopted as the By-laws of RIVER RUN OF SEASTYAN CONDOMINIUM ASSOCIATION, INC., a corporation not for profit under the laws of the State of Florida, at the first meeting of the Board of Directors on the 14th day of June, 1984.

APPROVED:

*Ann J. Muller*  
President

*Carole J. Muller*  
Secretary

COPY

COPY

COPY

JOINDER OF MORTGAGEE

CHASE MANHATTAN BANK, NATIONAL ASSOCIATION, a banking association organized and existing under the laws of the United States of America and having its principal place of business at 1 Chase Manhattan Plaza, New York, New York 10081, the owner and holder of that certain mortgage upon land described therein situate in Indian River County, Florida, which mortgage is recorded in O.R. Book 674 at page 872 of the Public Records of Indian River County, Florida, hereby joins in the making of the foregoing Declaration of Condominium, and Mortgagee agrees that the liens of its mortgage on the property described in said mortgage shall henceforth be upon the following described property in Indian River County, Florida in addition to and not in substitution for those lands described in that certain mortgage recorded in O.R. Book 674 at page 872 of the Public Records of Indian River County, Florida:

ALL UNITS in RIVER RUN DOCK, a Condominium, according to the Declaration of Condominium dated JUNE 1, 1987, and recorded in O.R. Book 674 at page 872 of the Public Records of Indian River County, Florida, together with the undivided interest in the common elements declared in said Declaration of Condominium to be an appurtenance to the above-described units.

TOGETHER WITH all of the appurtenances to the said Units, including, but not limited to all of the undivided shares in the common elements, and the percentage of the land as shown in the condominium documents as to each Unit.

Signed, sealed and delivered in the presence of:

CHASE MANHATTAN BANK, NATIONAL ASSOCIATION

*[Handwritten signature]*  
\_\_\_\_\_  
\_\_\_\_\_  
\_\_\_\_\_  
*[Handwritten signature]*

By: *[Handwritten signature]*  
\_\_\_\_\_  
JOHN J. TOTO  
SECOND VICE PRESIDENT  
(Corp. Seal)

STATE OF NEW YORK  
COUNTY OF NEW YORK

The foregoing instrument was acknowledged before me by John J. TOTO Second Vice President of CHASE MANHATTAN BANK, NATIONAL ASSOCIATION, a U.S. banking association, on behalf of the association, on this 30<sup>th</sup> day of JANUARY, 1988.

*[Handwritten signature]*  
\_\_\_\_\_  
Notary Public  
My Commission expires:

FRANCINE M. LAROSA  
Notary Public, State of New York  
No. 4046143  
Qualified in Kings County  
Commission Expires July 31, 1989

JOINDER OF MORTGAGEE

DONALD D. DORAN and LOUISE S. DORAN, his wife, the owners and holders of that certain mortgage upon land described therein situate in Indian River County, Florida, which mortgage is recorded in O.R. Book 674 at page 898 of the Public Records of Indian River County, Florida, hereby joins in the making of the foregoing Declaration of Condominium, and Mortgagee agrees that the liens of its mortgage on the property described in said mortgage shall henceforth be upon the following described property in Indian River County, Florida in addition to and not in substitution for those lands described in that certain mortgage recorded in O.R. Book 674 at page 898 of the Public Records of Indian River County, Florida:

ALL UNITS in RIVER RUN DOCK, a Condominium, according to the Declaration of Condominium dated JUNE 1, 1987, and recorded in O.R. Book 797 at page 342 of the Public Records of Indian River County, Florida, together with the undivided interest in the common elements declared in said Declaration of Condominium to be an appurtenance to the above-described units.

TOGETHER WITH all of the appurtenances to the said Units, including, but not limited to all of the undivided shares in the common elements, and the percentage of the land as shown in the condominium documents as to each unit.

Signed, sealed and delivered in the presence of:

Rebena de Oliveira Santos  
Conni S. Doran

Donald D. Doran  
Donald D. Doran  
Louise S. Doran  
Louise S. Doran

STATE OF FLORIDA  
COUNTY OF PALM BEACH

The foregoing instrument was acknowledged before me by DONALD D. DORAN and LOUISE S. DORAN, his wife, on this 04 day of JAN., 1988.

Conni S. Doran  
Notary Public, State of Florida  
at Large. My Commission expires:

My Commission Expires: Oct. 12, 1987

JOINDER OF MORTGAGEE

CHARLES E. MURPHY, as Trustee and individually, the owner and holder of that certain mortgage upon land described therein situate in Indian River County, Florida, which mortgage is recorded in O.R. Book 674 at page 912 of the Public Records of Indian River County, Florida, hereby joins in the making of the foregoing Declaration of Condominium, and Mortgagee agrees that the liens of its mortgage on the property described in said mortgage shall henceforth be upon the following described property in Indian River County, Florida in addition to and not in substitution for those lands described in that certain mortgage recorded in O.R. Book 674 at page 912 of the Public Records of Indian River County, Florida:

ALL UNITS in RIVER RUN DOCK, a Condominium, according to the Declaration of Condominium dated JUNE 1, 1987, and recorded in O.R. Book 797 at page 342 of the Public Records of Indian River County, Florida, together with the undivided interest in the common elements declared in said Declaration of Condominium to be an appurtenance to the above-described units.

TOGETHER WITH all of the appurtenances to the said Units, including, but not limited to all of the undivided shares in the common elements, and the percentage of the land as shown in the condominium documents as to each Unit.

Signed, sealed and delivered in the presence of:

[Signature]  
Lela Gregory

[Signature]  
Charles E. Murphy, as Trustee and individually

STATE OF Florida  
COUNTY OF Indian River

The foregoing instrument was acknowledged before me by CHARLES E. MURPHY, as Trustee and individually, on this 25th day of Feb, 1988.

[Signature]  
Notary Public  
My Commission expires:

Notary Public, State of Florida  
My Commission Expires March 7, 1990  
Bounded Lines Limit Error & Inaccuracy Only

Second Executed Original